



LS 72

Throughbeam photoelectric sensors



12m



- Slim construction with glass lens and robust metal housing for protection against environmental influences
- LEDs as switching state indicators
- Output is short-circuit proof and polarity reversal protected, thus guaranteeing riskless commissioning
- Mounting holes and M4 threads for fast front side mounting
- Connection via M12 connector, plug or cable



Accessories:

(available separately)

- Mounting systems (BT 92)
- M12 connectors (KD ...)
- Ready-made cables (KB ...)
- UMS 1

Dimensioned drawing

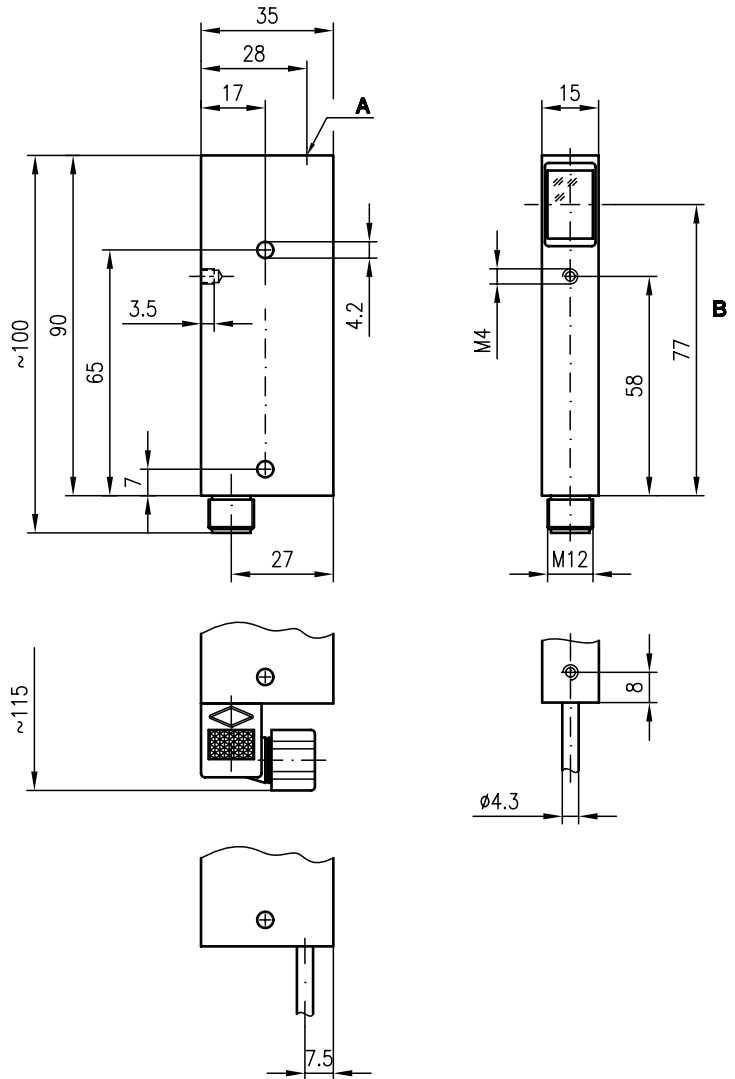

- A Indicator diode (only at receiver)
- B Optical axis

Electrical connection

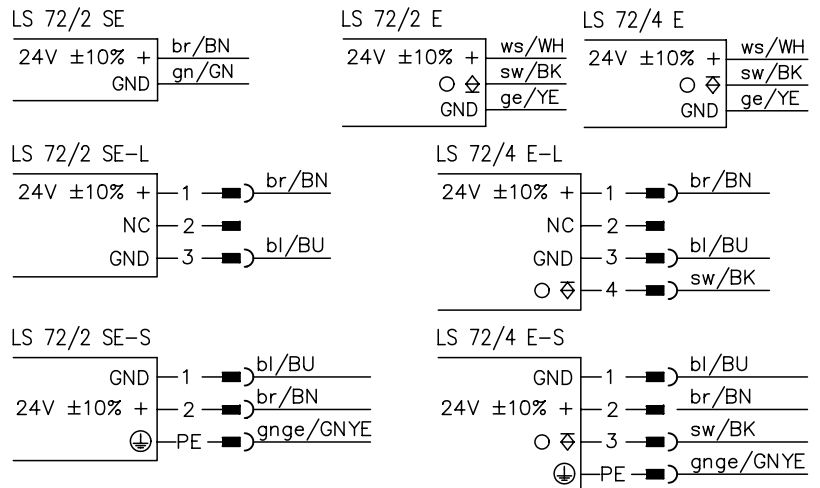

We reserve the right to make changes • 72_a01e.fm

Specifications

Optical data

Typ. operating range limit ¹⁾	0 ... 12m
Operating range ²⁾	0 ... 8m
Light source	LED (modulated light)
Wavelength	880nm (infrared)

Timing

Switching frequency	100Hz
Response time	5ms

Electrical data

Operating voltage U_B	24VDC \pm 10% (incl. residual ripple)
Residual ripple	\leq 15% of U_B
Bias current	\leq 50mA
Switching output	PNP or NPN transistor output
Function characteristics	light switching
Signal voltage high/low	$\geq (U_B - 3V) / \leq 2V$
Output current	max. 100mA

Indicators

LED green/red	green: light path free red: light path interrupted
---------------	---

Mechanical data

Housing	diecast
Weight	170g, cable device 480g
Optics	glass lens
Connection type	M12 connector 4-pin, plug 4-pin or cable (cross section 3x0.25mm ²)

Environmental data

Ambient temp. (operation/storage)	-20°C ... +60°C / -30°C ... +70°C
Protective circuit ³⁾	2, 3
Protection class	IP 67
LED class	1 (acc. to EN 60825-1)

1) Typ. operating range limit: max. attainable range without performance reserve

2) Operating range: recommended range with performance reserve

3) 2=polarity reversal protection, 3=short circuit protection

Tables

0	8	12
---	---	----

<input type="checkbox"/>	Operating range [m]
<input type="checkbox"/>	Typ. operating range limit [m]

Diagrams

Typ. response behaviour

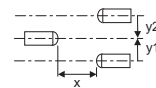
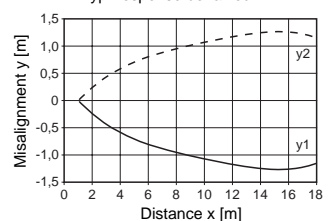

Order guide

Selection table		Order code →					
Equipment ↓		LS 72/2.6000	LS 72/4.6000	LS 72/4 L	LS 72/4 S		
		Part No. 500 00219 (Tr)	Part No. 500 00219 (Tr)	Part No. 500 18611 (Tr)	Part No. 500 06514 (Tr)		
		Part No. 500 00220 (Re)	Part No. 500 00223 (Re)	Part No. 500 18612 (Re)	Part No. 500 06515 (Re)		
Light source	infrared	●	●	●	●		
Connection	cable 6m	●	●				
	M12			●			
	standard plug 4-pin				●		
Indicator LED	top of housing	●	●	●	●		
Switching output	PNP		●	●	●		
	NPN	●					

Remarks



TLS 72

Throughbeam photoelectric sensor with testing



Dimensioned drawing

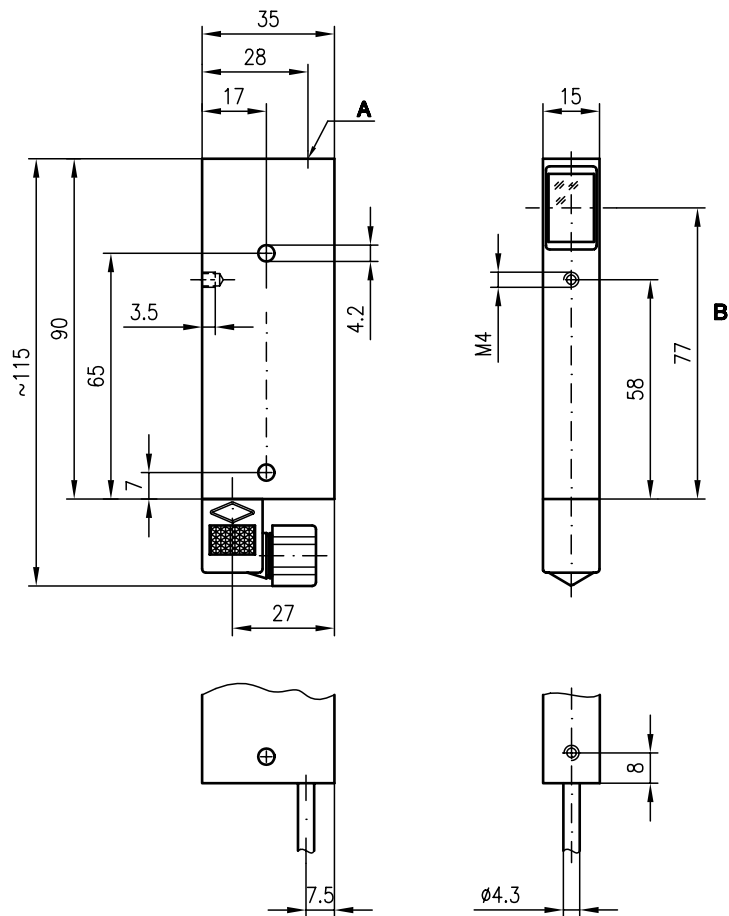

12m



- Slim construction with glass lens and robust metal housing for protection against environmental influences
- LEDs as switching state indicators
- Output is short-circuit proof and polarity reversal protected, thus guaranteeing riskless commissioning
- Mounting holes and M4 threads for fast front side mounting
- Connection via M12 connector, plug or cable
- Test input (active low)

A Indicator diode (only at receiver)
 B Optical axis

Electrical connection

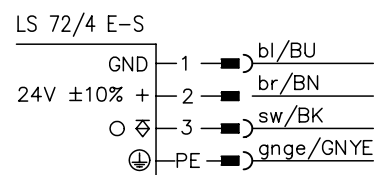
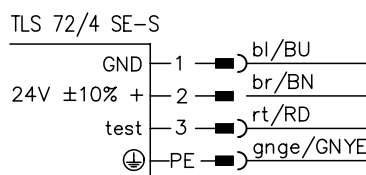
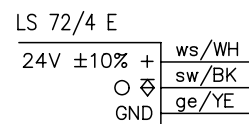
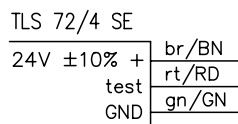

Accessories:

(available separately)

- Mounting systems (BT 92)
- M12 connectors (KD ...)
- Ready-made cables (KB ...)



We reserve the right to make changes • 72_a02e.fm



Specifications

Optical data

Typ. operating range limit ¹⁾	0 ... 12m
Operating range ²⁾	0 ... 8m
Light source	LED (modulated light)
Wavelength	880nm (infrared)

Timing

Switching frequency	100Hz
Response time	5ms

Electrical data

Operating voltage U _B	24VDC ± 10% (incl. residual ripple)
Residual ripple	≤ 15% of U _B
Bias current	≤ 70mA
Switching output	PNP transistor output
Function characteristics	light switching
Signal voltage high/low	≥ (U _B -3V)/≤ 2V
Output current	max. 100mA

Indicators

LED green/red	green: light path free red: light path interrupted
---------------	---

Mechanical data

Housing	diecast
Weight	170g, cable device 480g
Optics	glass lens
Connection type	M12 connector 4-pin, plug 4-pin or cable (cross section 3x0.25mm ²)

Environmental data

Ambient temp. (operation/storage)	-20°C ... +60°C/-30°C ... +70°C
Protective circuit ³⁾	2, 3
Protection class	IP 67
LED class	1 (acc. to EN 60825-1)

Options

Test input (active low)	
Transmitter active/not active	≥ (U _B -3V)/≤ 2V

- 1) Typ. operating range limit: max. attainable range without performance reserve
- 2) Operating range: recommended range with performance reserve
- 3) 2=polarity reversal protection, 3=short circuit protection

Tables

0	8	12
---	---	----

- Operating range [m]
- Typ. operating range limit [m]

Diagrams

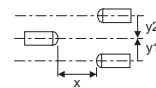
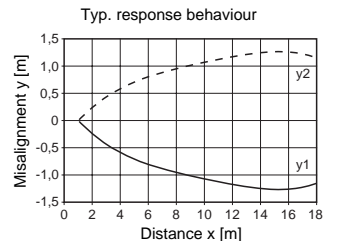

Order guide

Selection table		Order code →				
Equipment ↓		TLS 72/4,6000 Part No. 500 03364 (Tr) Part No. 500 00223 (Re)	TLS 72/4 S Part No. 500 06516 (Tr) Part No. 500 06515 (Re)			
Light source	infrared	●	●			
Connection	cable 6m	●				
	M12					
	standard plug 4-pin		●			
Indicator LED	top of housing	●	●			
Features	test input (low active)	●	●			

Remarks



RK 72

Retro-reflective photoelectric sensors



0 ... 6m

12 - 30 V
DC

- Slim construction with glass lens and robust metal housing for protection against environmental influences
- LEDs as switching state indicators
- Output is short-circuit proof and polarity reversal protected, thus guaranteeing riskless commissioning
- Mounting holes and M4 threads for fast front side mounting
- Connection via M12 connector, plug or cable



ISO 9001



Accessories:

(available separately)

- Mounting systems (BT 92)
- M12 connectors (KD ...)
- Ready-made cables (KB ...)

Dimensioned drawing

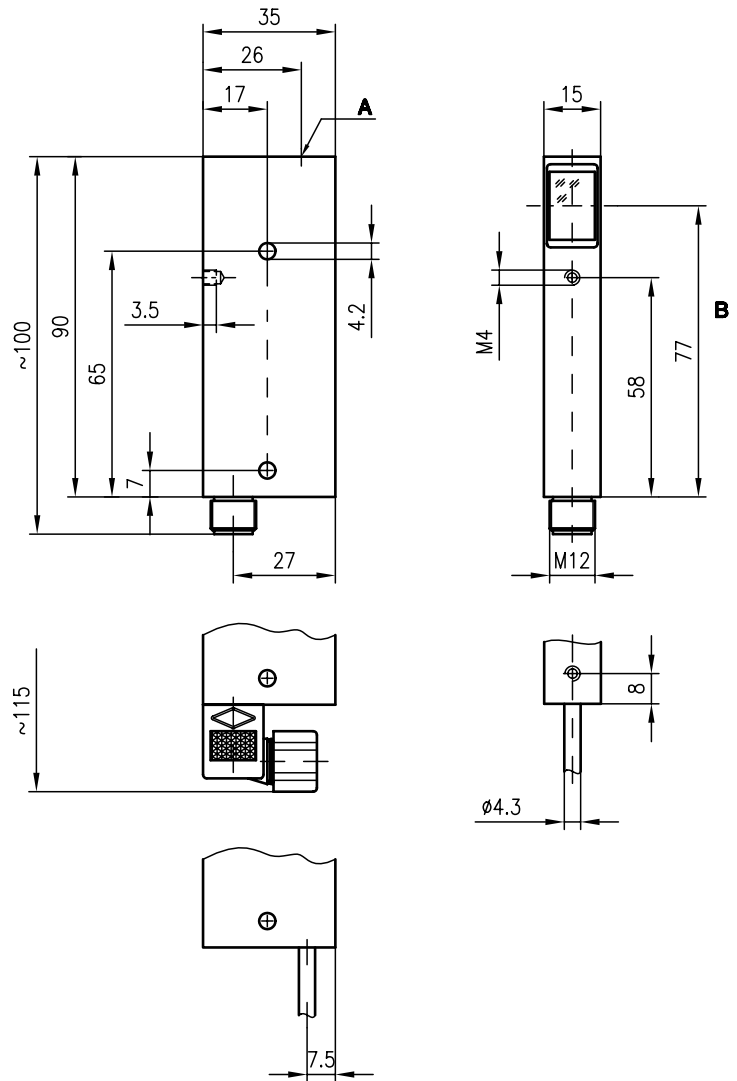

- A Indicator diode
- B Optical axis

Electrical connection

RK 72/2

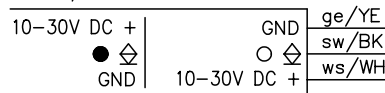

RK 72/4

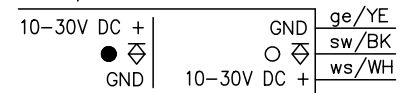

RK 72/4 L

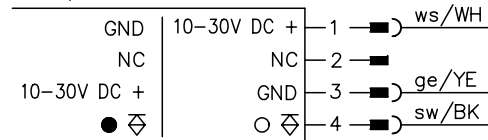

RK 72/4 S

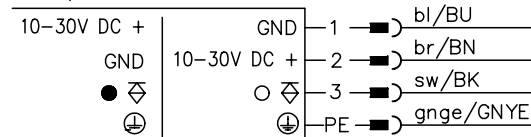



Specifications

Optical data

Typ. operating range limit (TK(S) 100x100) ¹⁾ 0 ... 6m
 Operating range ²⁾ see tables
 Light source LED (modulated light)
 Wavelength 880nm (infrared)

Timing

Switching frequency 100Hz
 Response time 5ms

Electrical data

Operating voltage U_B 12 ... 30VDC (incl. residual ripple)
 Residual ripple ≤ 15% of U_B
 Bias current ≤ 50mA
 Switching output PNP or NPN transistor output
 Function characteristics light/dark switching by reversing the polarity
 Signal voltage high/low ≥ (U_B-3V) ≤ 2V
 Output current max. 100mA

Indicators

LED red light path free
 LED red flashing no performance reserve

Mechanical data

Housing diecast
 Weight 150g
 Optics glass lens
 Connection type M12 connector 4-pin, plug 4-pin or cable (cross section 4x0.25mm²)

Environmental data

Ambient temp. (operation/storage) -20°C ... +60°C/-30°C ... +70°C
 Protective circuit ³⁾ 2, 3
 Protection class IP 67
 LED class 1 (acc. to EN 60825-1)

1) Typ. operating range limit: max. attainable range without performance reserve
 2) Operating range: recommended range with performance reserve
 3) 2=polarity reversal protection, 3=short circuit protection

Tables

Reflectors	Operating range
1 TK(S) 100x100	0.1 ... 4m
2 MTK(S) 50x50	0.1 ... 3.5m
3 TK(S) 30x50	0.1 ... 2.5m
4 TK(S) 20x40	0.1 ... 2m
5 Tape 2 100x100	0.1 ... 3m

1 0.1	4	6
2 0.1	3.5	5
3 0.1	2.5	3
4 0.1	2	2.5
5 0.1	3	3.5

□ Operating range [m]
 ▒ Typ. operating range limit [m]

TK ... = adhesive
 TKS ... = screw type
 Tape 2 = adhesive

Diagrams

Typ. response behaviour (TKS 100x100)

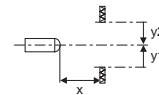
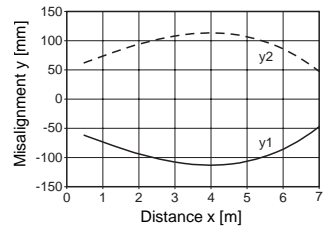

Order guide

Selection table		Order code →				
Equipment ↓		RK 72/2 Part No. 500 00396	RK 72/4 Part No. 500 00413	RK 72/4,5000 Part No. 500 00415	RK 72/4 L Part No. 500 17372	RK 72/4 S Part No. 500 00419
Light source	infrared	●	●	●	●	●
Connection	cable 2m	●	●			
	cable 5m			●		
	cable 6m					
	M12				●	
	standard plug 4-pin					●
Indicator LED	top of housing	●	●	●	●	●
Features	light/dark by reversing the polarity	●	●	●	●	●

Remarks



Specifications

Optical data

Typ. operating range limit (TK(S) 100x100) ¹⁾ 0.1 ... 6m
 Operating range ²⁾ see tables
 Light source LED (modulated light)
 Wavelength 660nm (red light)

Timing

Switching frequency 200Hz
 Response time 2.5ms

Electrical data

Operating voltage U_B 10 ... 30VDC (incl. residual ripple)
 Residual ripple $\leq 15\%$ of U_B
 Bias current ≤ 100 mA
 Switching output PNP or NPN transistor output
 Function characteristics light/dark switching by reversing the polarity
 Signal voltage high/low $\geq (U_B - 3V) \leq 2V$
 Output current max. 100mA

Indicators

LED red light path free
 LED red flashing no performance reserve

Mechanical data

Housing diecast
 Weight 130g
 Optics glass lens
 Connection type M12 connector 4-pin, plug 4-pin or cable (cross section 4x0.25mm²)

Environmental data

Ambient temp. (operation/storage) -20°C ... +60°C / -30°C ... +70°C
 Protective circuit ³⁾ 2, 3
 Protection class IP 67
 LED class 1 (acc. to EN 60825-1)

1) Typ. operating range limit: max. attainable range without performance reserve
 2) Operating range: recommended range with performance reserve
 3) 2=polarity reversal protection, 3=short circuit protection

Tables

Reflectors			Operating range
1	TK(S)	100x100	0.1 ... 4m
2	MTK(S)	50x50	0.1 ... 3.5m
3	TK(S)	30x50	0.1 ... 2.5m
4	TK(S)	20x40	0.1 ... 2m
5	Tape 2	100x100	0.1 ... 2.2m

1	0.1		4	6
2	0.1		3.5	4.5
3	0.1	2.5	3	
4	0.1	2	2.5	
5	0.1	2.2	2.5	

Operating range [m]
 Typ. operating range limit [m]

TK ... = adhesive
 TKS ... = screw type
 Tape 2 = adhesive

Diagrams

Typ. response behaviour (TKS 100x100)

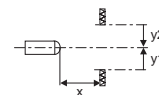
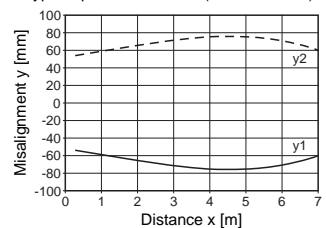

Order guide

Selection table		Order code →				
Equipment ↓		PRK 72/2 Part No. 500 00596	PRK 72/4 Part No. 500 00597	PRK 72/4,5000 Part No. 500 06537	PRK 72/4 L Part No. 500 17527	PRK 72/4 S Part No. 500 06538
Light source	red light	●	●	●	●	●
Connection	cable 2m	●	●			
	cable 5m			●		
	cable 6m					
	M12				●	
	standard plug 4-pin					●
Indicator LED	top of housing	●	●	●	●	●
Features	light/dark by reversing the polarity	●	●	●	●	●
	polarisation	●	●	●	●	●

Remarks

RK 72

Energetic diffuse reflection light scanner

Part No. 501 10271



10 ... 200mm



- Slim construction with glass lens and robust metal housing for protection against environmental influences
- LEDs as switching state indicators
- Output is short-circuit proof and polarity reversal protected, thus guaranteeing riskless commissioning
- Mounting holes and M4 threads for fast, front-side mounting
- Connection via cable



Accessories:

(available separately)

- Mounting systems (BT 92)
- M12 connectors (KD ...)

Dimensioned drawing

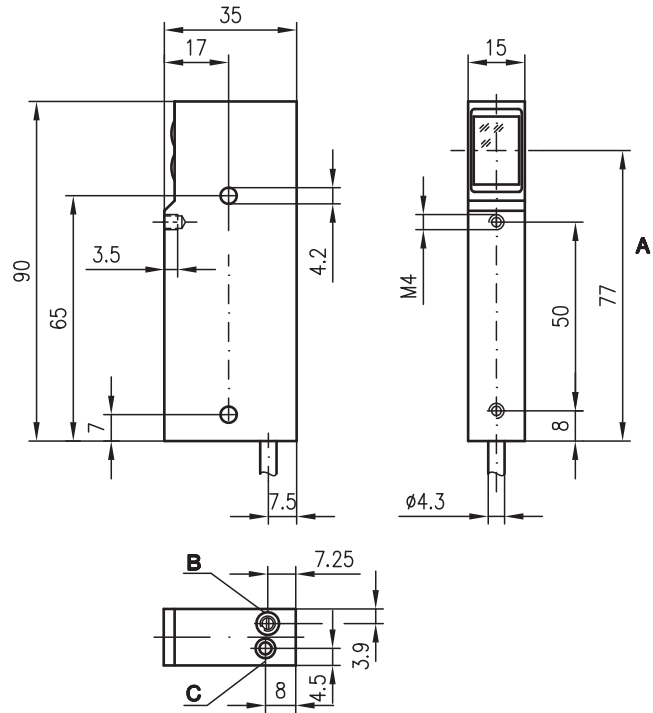

- A** Optical axis
- B** Sensitivity adjustment
- C** Indicator diode

Electrical connection

RK 72/2-200

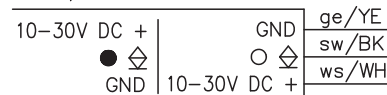

RK 72/4-200

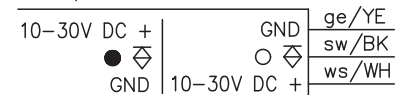

We reserve the right to make changes * 72_c01gb.fm

Specifications

Optical data

Typ. scanning range limit (white 90%) ¹⁾
 Scanning range ²⁾
 Light source
 Wavelength

RK 72 ...
 0 ... 340mm
 0 ... 200mm
 LED (modulated light)
 880nm (infrared)

Timing

Switching frequency
 Response time

100Hz
 5ms

Electrical data

Operating voltage U_B
 Residual ripple
 Bias current
 Switching output
 Function characteristics
 Signal voltage high/low
 Output current
 Sensitivity

12 ... 30VDC (incl. residual ripple)
 $\leq 15\%$ of U_B
 ≤ 50 mA
 PNP or NPN transistor output
 light/dark switching by reversing the polarity
 $\geq (U_B - 3V) \leq 2V$
 max. 100mA
 adjustable with 270° potentiometer

Indicators

LED red

reflection

Mechanical data

Housing
 Weight
 Optics
 Connection type

diecast
 150g
 glass lens
 cable (cross section 4x0.25mm²)

Environmental data

Ambient temp. (operation/storage)
 Protective circuit ³⁾
 Protection class
 LED class

-20°C ... +60°C/-30°C ... +70°C
 2, 3
 IP 67
 1 (acc. to EN 60825-1)

- 1) Typ. scanning range limit: max. attainable range without performance reserve
- 2) Scanning range: recommended range with performance reserve
- 3) 2=polarity reversal protection, 3=short circuit protection

Tables

1	0	200	340
2	8	140	250
3	10	110	200

1	white 90%
2	grey 18%
3	black 6%

Scanning range [mm]
 Typ. scanning range limit [mm]

Diagrams

Typ. response behaviour (white 90%)

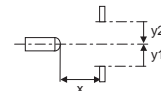
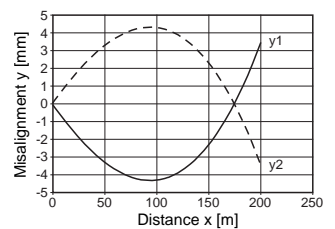

Typ. black/white behaviour

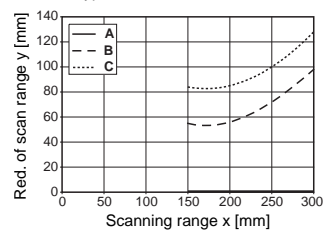

- A white 90%
- B grey 18%
- C black 6%

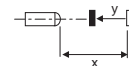

Order guide

Selection table		Order code →			
Equipment ↓		RK 72/2-200 Part No. 500 00408	RK 72/2-200,5000 Part No. 500 00409	RK 72/4-200 Part No. 500 00420	RK 72/4-200,5000 Part No. 500 06626
Light source	infrared	●	●	●	●
Connection	cable 2m	●		●	
	cable 5m		●		●
Indicator LED	top of housing	●	●	●	●
Features	label detection on glass				
	sensitivity adjustment 270°	●	●	●	●
	light/dark by reversing the polarity	●	●	●	●

Remarks

Approved purpose:

The diffuse reflection light scanners are optical electronic sensors for optical, contactless detection of objects.

- The upper and lower scanning range limits can change with poorly reflecting materials.

RK 72

Energetic diffuse reflection light scanner

Part No. 501 10269



10 ... 200mm



- Robust metal housing with glass lens
- For the detection of paper, sleeve and adhesive labels on glass and PET bottles
- Sensitivity adjustment

Dimensioned drawing

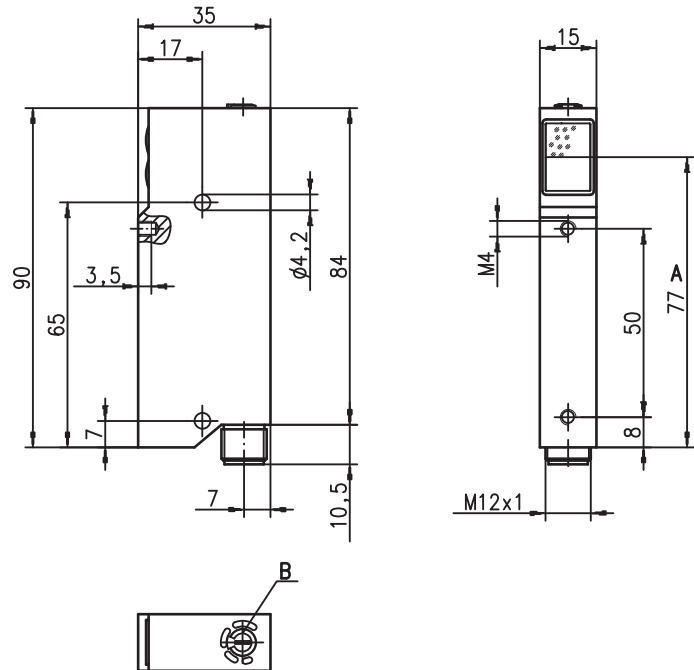

- A Indicator diode
- B Sensitivity adjustment

Electrical connection

RK 72/4-200 L.2

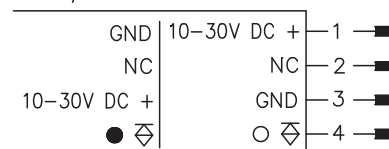

We reserve the right to make changes * 72_c03gb.fm



Accessories:

(available separately)

- Mounting systems (BT 92)
- M12 connectors (KD ...)
- Ready-made cables (KB ...)

Specifications

Optical data

Typ. scanning range limit (white 90%) ¹⁾	0 ... 340mm
Scanning range ²⁾	0 ... 200mm
Label scanning range	25 ... 50mm
Light source	LED (modulated light)
Wavelength	880nm (infrared)

Timing

Switching frequency	150Hz
Response time	3.3ms

Electrical data

Operating voltage U_B	12 ... 30VDC (incl. residual ripple)
Residual ripple	$\leq 15\%$ of U_B
Open-circuit current	≤ 50 mA
Switching output	PNP transistor output
Function characteristics	light/dark switching by reversing the polarity
Signal voltage high/low	$\geq (U_B - 3V) / \leq 2V$
Output current	max. 100mA
Sensitivity	adjustable with 270° potentiometer

Indicators

Yellow LED	reflection
------------	------------

Mechanical data

Housing	diecast
Weight	150g
Optics	glass lens
Connection type	M12 connector, 4-pin
Fitting position	inclined position $15^\circ \pm 5^\circ$ (see fitting position drawing)

Environmental data

Ambient temp. (operation/storage)	$-20^\circ\text{C} \dots +60^\circ\text{C} / -30^\circ\text{C} \dots +70^\circ\text{C}$
Protective circuit ³⁾	2, 3
Protection class	IP 67
LED class	1 (acc. to EN 60825-1)

- 1) Typ. scanning range limit: max. attainable range without performance reserve
 2) Scanning range: recommended range with performance reserve
 3) 2=polarity reversal protection, 3=short circuit protection

Preferred fitting position

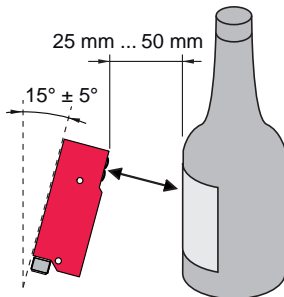

Order guide

Selection table		Order code →	RK 72/4-200 L.2 Part No. 501 09617			
Equipment ↓						
Light source	infrared		●			
Connection	cable 2m					
	cable 5m					
	cable 6m					
	M12		●			
	4-pin standard plug					
Indicator LED	top of housing		●			
Features	label detection		●			
	sensitivity adjustment 270°		●			
	light/dark by reversing the polarity		●			

Tables

1	0	200	340
2	8	140	250
3	10	110	200

1	white 90%
2	grey 18%
3	black 6%

□ Scanning range [mm]
 □ Typ. scanning range limit [mm]

Diagrams

Typ. response behaviour (white 90%)

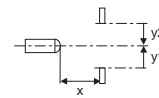
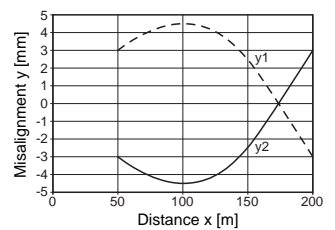

Typ. black/white behaviour

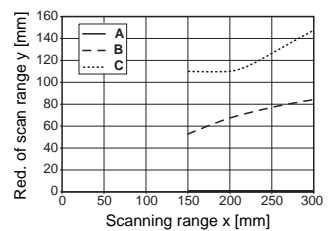

- A white 90%
- B grey 18%
- C black 6%

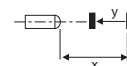

Remarks

Approved purpose:

The diffuse reflection light scanners are optical electronic sensors for optical, contactless detection of objects.

- Please note the preferred fitting position!
- There are bottle/contents/label combinations which cannot be detected reliably