



Barcode positioning system BPS 34 for the PROFIBUS DP

Technical Description



© All rights reserved, especially the right of reproduction and translation.
This document may not be duplicated or reproduced in any form without the written permission of
Leuze electronic GmbH + Co. KG
It is subject to changes due to technical progress.

1	General information	3
1.1	Explanation of symbols	3
1.2	Declaration of conformity	3
1.3	Description of the BPS 34 functions	4
2	Safety notices	5
2.1	General safety notices	5
2.2	Safety standards	5
2.3	Intended use	5
2.4	Working safely	6
3	Commissioning steps at a glance	8
4	Specifications BPS 34	13
4.1	General specifications BPS 34	13
4.2	Dimensioned drawings.....	14
4.3	Electrical connection	16
4.3.1	PWR IN - voltage supply and switching input/output	18
4.3.2	DP IN - PROFIBUS DP incoming	19
4.3.3	DP OUT - PROFIBUS DP outgoing.....	19
4.3.4	SW IN/OUT - switching input/switching output	20
4.3.5	BPS 34 reading field curve.....	21
5	Connector units MS 34 ... / MSD 1 101	22
5.1	Modular hoods with integrated connectors MS 34 103 and MS 34 105	22
5.1.1	General information	22
5.1.2	Specifications of the connector units	22
5.1.3	Dimensioned drawings	23
5.1.4	Electrical connection	24
5.1.5	Description of the LED states	24
5.2	Modular Service Display MSD 1 101	25
5.2.1	General information	25
5.2.2	Dimensioned drawing	26
5.2.3	Electrical connection	26
6	Barcode tape	27
6.1	General information	27
6.2	Specifications of the barcode tape	28
6.3	Mounting the barcode tape	29
6.4	Control barcode	32
6.4.1	Controllable functions	33
6.5	Repair kit.....	35
7	Mounting	37
7.1	Mounting the BPS 34	37
7.2	Device arrangement.....	40
7.3	Mounting the barcode tape	41

8	Device parameters and interfaces	42
8.1	PROFIBUS.....	42
8.1.1	General information.....	42
8.1.2	Electrical connection.....	42
8.1.3	PROFIBUS address.....	45
8.1.4	General information on the GSE file.....	45
8.1.5	Structure of the GSE modules.....	46
8.1.6	Overview of the GSE modules.....	47
8.1.7	Detailed description of the modules.....	50
9	Diagnostics and troubleshooting	92
9.1	General causes of errors.....	92
9.2	PROFIBUS errors.....	92
10	Type overview and accessories	94
10.1	Type overview: BPS 34.....	94
10.2	Accessory modular hoods with integrated connectors.....	94
10.3	Accessory modular service display.....	94
10.4	Accessory termination.....	94
10.5	Accessory connectors.....	94
10.6	Accessory mounting device.....	94
10.7	Accessory ready-made cables for voltage supply.....	95
10.7.1	Contact assignment of PWR IN connection cable.....	95
10.7.2	Specifications of voltage supply cable.....	95
10.7.3	Order codes for voltage supply cables.....	95
10.8	Accessory ready-made cables for PROFIBUS connection.....	96
10.8.1	General.....	96
10.8.2	Contact assignment for PROFIBUS connection cable KB PB.....	96
10.8.3	Specifications of PROFIBUS connection cable.....	97
10.8.4	Order codes for PROFIBUS connection cables.....	97
10.9	Type overview: Barcode tape.....	98
11	Maintenance	99
11.1	General maintenance information.....	99
11.2	Repairs, servicing.....	99
11.3	Disassembling, packing, disposing.....	99
12	Appendix	100
12.1	EU Declaration of Conformity.....	100

1 General information

1.1 Explanation of symbols

The symbols used in this operating manual are explained below.



Attention!

This symbol appears before text passages which must absolutely be observed. Failure to heed this information can lead to injuries to personnel or damage to the equipment.



Attention Laser!

This symbol warns of possible danger through hazardous laser radiation.



Notice!

This symbol indicates text passages containing important information.

1.2 Declaration of conformity

The barcode positioning system BPS 34, the modular hood with integrated connectors MS 34 103/MS 34 105, and the optional modular service display MSD 1 101 have been developed and manufactured under observation of the applicable European standards and directives.

The devices of the BPS 34 series also fulfil the cUL requirements (Underwriters Laboratory Inc.) for the USA and Canada.



Notice!

A copy of all declarations of conformity available for the product can be found in the appendix of this handbook (see chapter 12.1 "EU Declaration of Conformity" on page 100).

The manufacturer of the product, Leuze electronic GmbH + Co. KG in D-73277 Owen/Teck, possesses a certified quality assurance system in accordance with ISO 9001.



1.3 Description of the BPS 34 functions

The BPS 34 uses visible red laser light to determine its position relative to the barcode tape. This essentially takes place in three steps:

1. Reading a code on the barcode tape
2. Determining the position of the read code in the scanning area of the scanning beam
3. Calculating the position to within a millimetre using the code information and the code position relative to the device's centre.

The position value is then output via the interface.

2 Safety notices

2.1 General safety notices

Documentation

All entries in this technical description must be heeded, in particular those in section "Safety notices". Keep this technical description in a safe place. It should be accessible at all times.

Safety regulations

Observe the locally applicable legal regulations and the rules of the employer's liability insurance association.

Repair

Repairs must only be carried out by the manufacturer or an authorised representative.

2.2 Safety standards

The devices of the BPS 34 series were developed, manufactured and tested in accordance with the applicable safety standards. They correspond to the state of the art.

2.3 Intended use

Barcode positioning systems of the BPS 34 series are optical measuring systems which use visible red laser light to determine the position of the BPS relative to a permanently mounted barcode tape.

The modular hoods with integrated connectors MS 34 103/MS 34 105 are intended for the easy connection of barcode positioning systems of type BPS 34 in a PROFIBUS system.

The modular service display MSD 1 101, which is optionally available, displays operational data of the BPS 34 and is used as a simple means of access to the service interface of the MS 34 105.

In particular, unauthorised uses include:

- rooms with explosive atmospheres
- operation for medical purposes



Attention!

The protection of personnel and the device is guaranteed only if the device is operated in a manner corresponding to its intended use.

Areas of application

The barcode positioning system BPS 34 has been developed for positioning tasks in the following areas of application:

- High-bay storage devices: Positioning in the travel and lifting axes
- Crane bridges and trolleys
- Side-tracking skates
- Telfer lines
- Lifts

2.4 Working safely



Attention!

Access to or changes on the device, except where expressly described in this operating manual, are not authorised.

Safety Regulations

Observe the locally applicable legal regulations and the rules of the employer's liability insurance association.

Qualified personnel

Mounting, commissioning and maintenance of the device may only be carried out by qualified personnel.

Electrical work must be carried out by a certified electrician.



Attention, laser radiation!

Warning: *The barcode positioning system BPS 34 operates with a red light laser of class 2 acc. to EN 60825-1. If you look into the beam path over a longer time period, the retina of your eye may be damaged!*

Never look directly into the beam path!

Do not point the laser beam of the BPS 34 at persons!

When mounting and aligning the BPS 34, take care to avoid reflections of the laser beam off reflective surfaces!

Heed the laser safety regulations according to DIN EN 60825-1 in their most current version! The output power of the laser beam at the reading window is at most 1.8mW acc. to EN 60825-1.

The BPS 34 uses a laser diode with low power in the visible red light range with an emitted wavelength of 650 ... 690nm.



Attention!

CAUTION! *The use of operating and adjusting devices other than those specified here or carrying out of differing procedures may lead to dangerous exposure to radiation!*

The barcode positioning system BPS 34 is provided with the following warning notices on the housing, as well as below and next to the reading window:

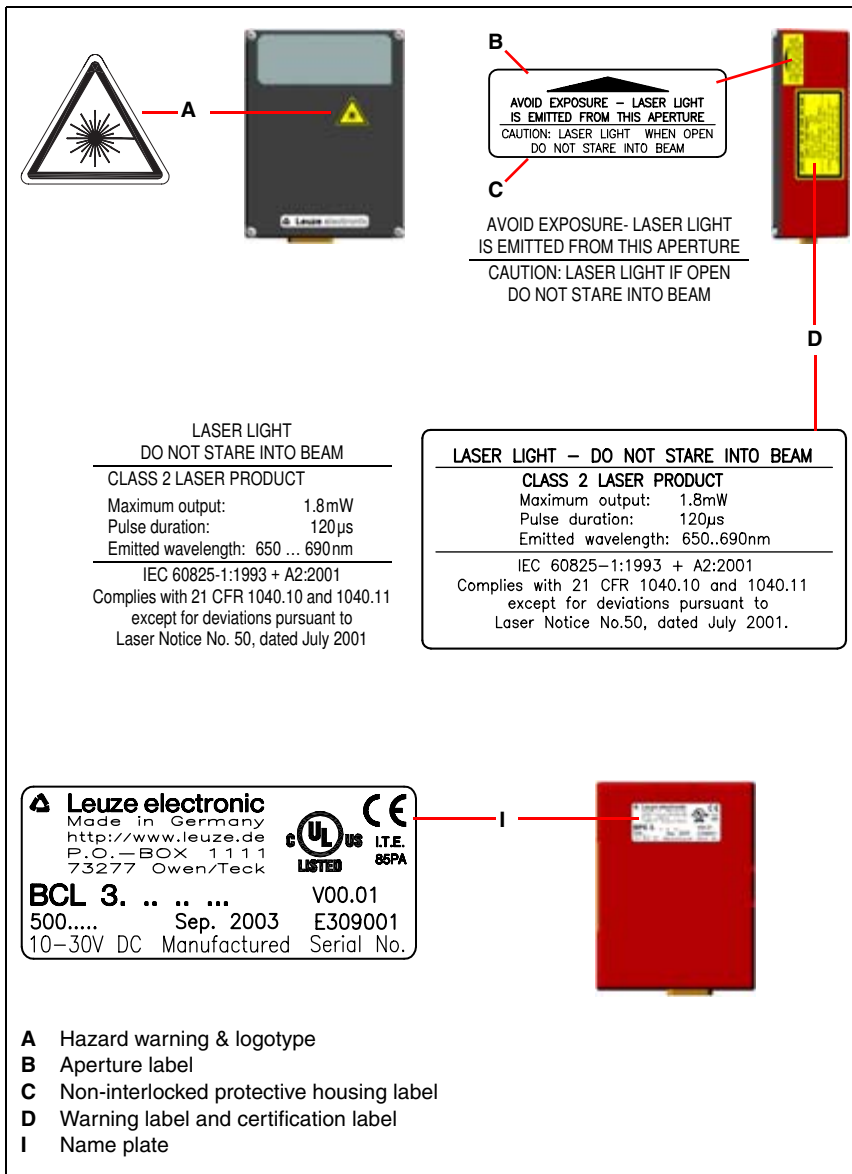

Figure 2.1: Attachment of the sticky labels with warning notices at the BPS 34

3 Commissioning steps at a glance



Notice!

Below you will find a **short description for the initial commissioning** of the barcode positioning system BPS 34. Detailed explanations for all listed points can be found throughout the handbook.

1

Mechanical design

Mounting the barcode tape

The barcode tape is to be affixed without tension to a dust- and grease-free mounting surface.

→ chapter 6.3 on page 29

Mounting the BPS 34 device

There are two different types of mounting arrangements for the BPS 34:

1. Using 4 M4x6 screws on the rear of the device.
2. Using a mounting device (BT 56) on the dovetail fastening grooves.



Notice!

The installation dimensions listed in the following figure must absolutely be adhered to. Optically, it must be ensured that the scanner has an unobstructed view of the barcode tape at all times. → chapter 7.2 on page 40

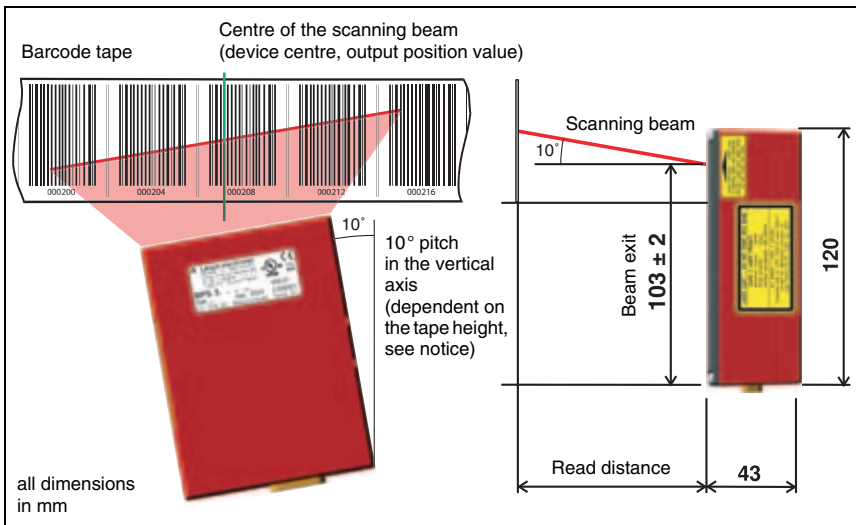

Figure 3.1: Beam exit and device arrangement of the BPS 34

→ chapter 7.1 on page 37



Notice!

During mounting, the following angles of inclination must be taken into account in the vertical axis:

10° for a tape height of 47 mm,

7° for a tape height of 30 mm and

5° for a tape height of 25 mm; the working range of the reading field curve must also be taken into account.



Attention!

For the position calculation, the scanning beam of the BPS 34 must be incident on the barcode tape without interruption. Ensure that the scanning beam is always incident on the barcode tape when the system is moving.



Connecting the voltage supply and PROFIBUS

The BPS 34, in combination with an MS 34 103 or MS 34 105, is connected via M12 connectors.

Connecting the voltage supply

The voltage supply is connected via the **PWR IN** M12 connection.

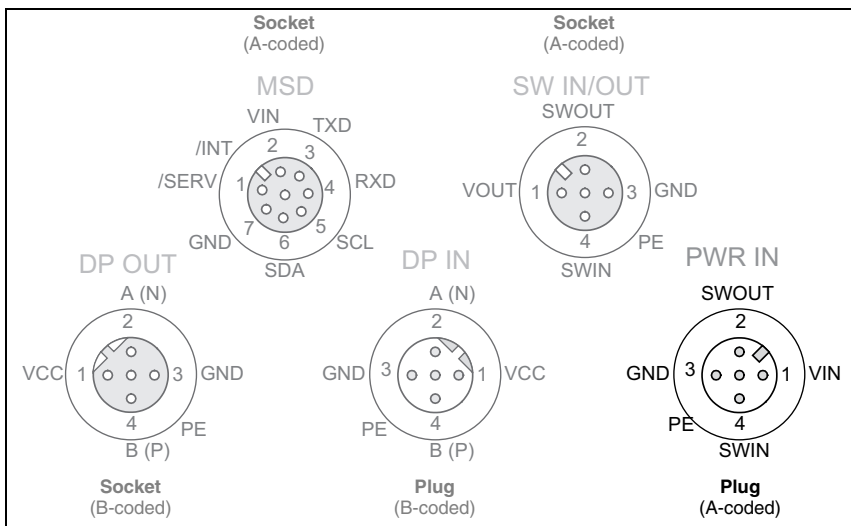

Figure 3.2: BPS 34 with MS 34 103/MS 34 105 - Connection PWR IN

Connecting the PROFIBUS

The PROFIBUS is connected via **DP IN** or, in the case of a continuing network, via **DP OUT**. If **DP OUT** is not used, the PROFIBUS must be terminated at this point with an M12 terminator plug (see chapter 10.4 "Accessory termination").

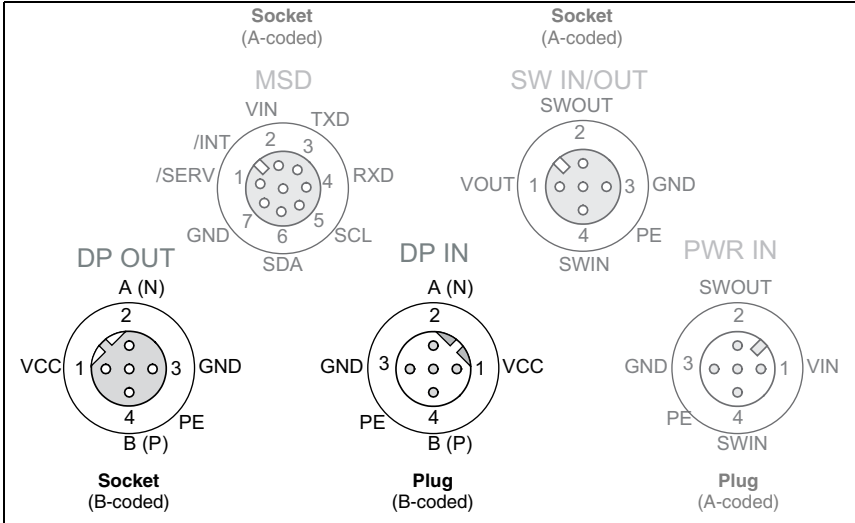

Figure 3.3: BPS 34 with MS 34 103/MS 34 105 - Connections DP IN and DP OUT

Setting the PROFIBUS address

The PROFIBUS address must be set in the MS 34 10x connector plug hood. The correct address setting on the PROFIBUS network is indicated by the green LED on the MS 34 10x.

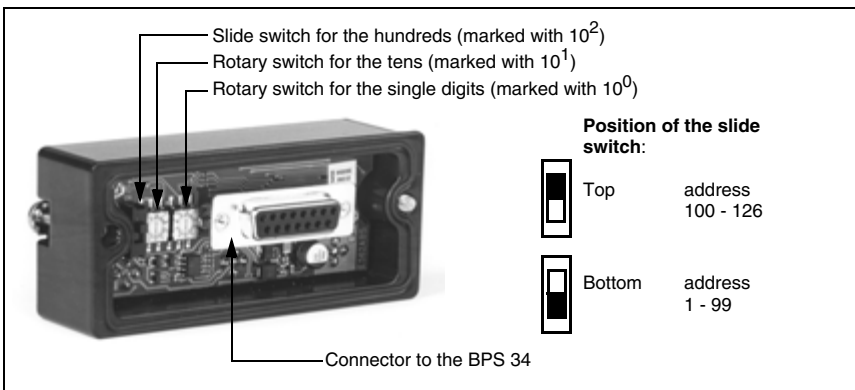

Figure 3.4: View of the inside of the MS 34

PROFIBUS manager

Install the GSE file associated with the BPS 34... in the PROFIBUS manager of your control. Activate the desired modules (at least module 1 - position value).

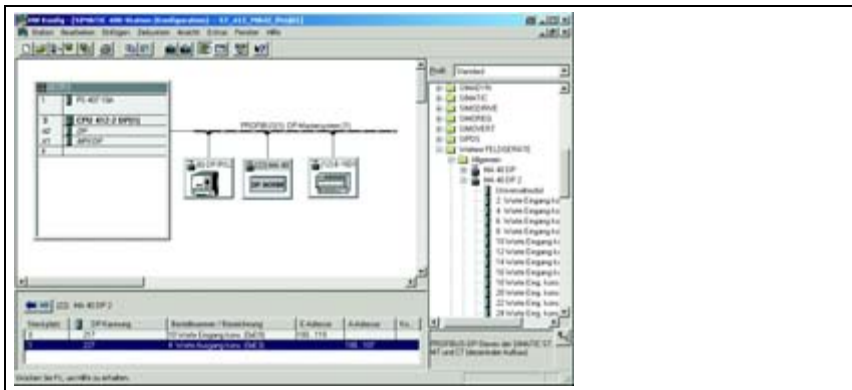

Figure 3.5: Example PROFIBUS manager

Store the slave address for the BPS 34 in the PROFIBUS manager. Ensure that the address is the same as the address configured in the device.

3

Connecting the switching input/switching output at the BPS 34

The switching input/switching output is connected via SW IN/OUT.

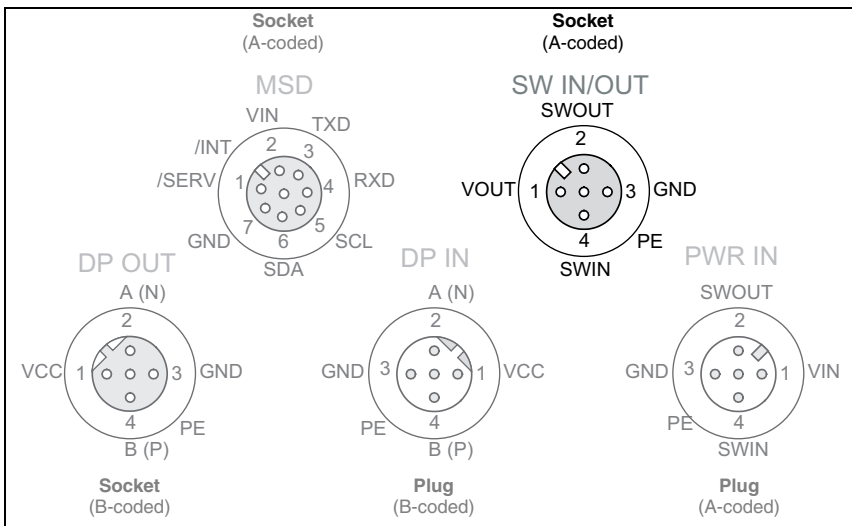

Figure 3.6: BPS 34 with MS 34 103/MS 34 105 - Connection SW IN/OUT

4

Connecting the Modular Service Display MSD 1 101

The MSD 1 101 is connected via cable KB 034-2000 (M12 connection on MSD and M12 connection on MSD 1 101, see chapter 10.3 "Accessory modular service display" on page 94).

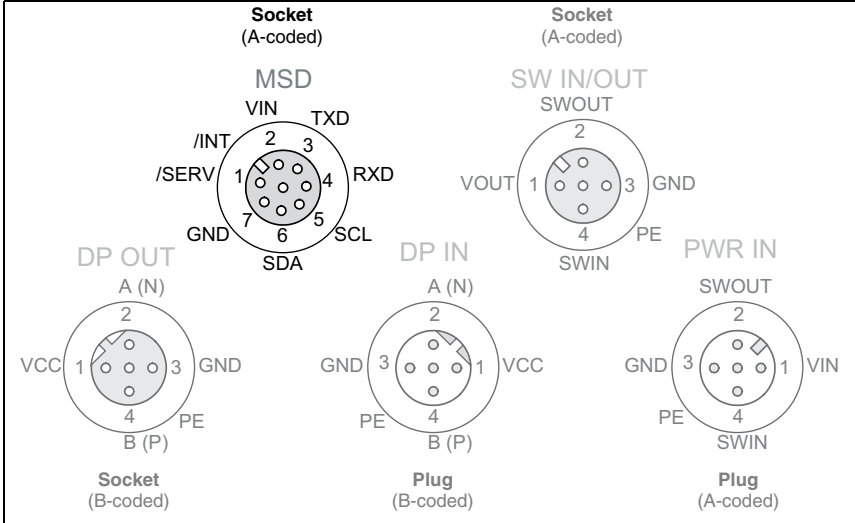

Figure 3.7: BPS 34 with MS 34 103/MS 34 105 - Connection MSD

The BPS 34 can be accessed via the MS 1 101 using the service interface.



Notice!

Changes which were made via the service interface on the BPS 34 are lost following initialisation on the PROFIBUS.

4 Specifications BPS 34

4.1 General specifications BPS 34

Optical data

Light source	Laser diode 650nm
Beam deflection	by means of rotating polygon mirror wheel
Reading distance	see reading field (figure 4.3.5)
Optical window	glass with scratch-resistant Indium coating
Laser safety class	2 acc. to EN 60825-1 ¹⁾ , II acc. to CDRH (U.S. 21 CFR 1040.10 and 1040.11)

Measurement data

Reproducible accuracy	±1 (2)mm
Integration time	16 (8)ms
Measurement value output	2ms (500 values/s)
Working range	90 ... 170mm
Max. traverse rate	10m/s

Electrical data

Interface type	PROFIBUS DP, up to 12MBd
Service interface	RS 232 with default data format 9600Bd, 8 data bits, no parity, 1 stop bit
Switching input / output	1 switching input, 1 switching output, each is programmable
LED green	device ready (power on) and bus O.K.
Operating voltage	without optics heating: 10 ... 30VDC with optics heating: 22 ... 26VDC ²⁾
Power consumption	without optics heating: 5W with optics heating: max. 30W

Mechanical data

Protection class	IP 65 ³⁾
Weight	without optics heating: 400g with optics heating: 480g
Dimensions (W x H x D)	without optics heating: 120 x 90 x 43mm with optics heating: 120 x 90 x 52mm
Housing	diecast aluminium

Environmental data

Operating temperature range	without optics heating: 0°C ... +40°C with optics heating: -30°C ... +40°C High temperature version: 0°C ... +50°C
Storage temperature range	-20°C ... +60°C
Air humidity	max. 90% rel. humidity, non-condensing
Vibration	IEC 60068-2-6, test FC
Shock	IEC 60068-2-27, test Ea
Continuous shock	IEC 60068-2-29, test Eb
Electromagnetic compatibility	EN 55022, EN 55024, EN 61000-4-2, -3, -4 and -6, EN 61000-6-2 and -3 ¹⁾

Barcode tape

Max. length	10000m
(measurement length)	
Ambient temperature	-40°C ... +120°C
Mech. properties	scratch and wipe resistant, UV resistant, moisture resistant, partly chemical resistant

- 1) For details see Declaration of Conformity on page 100
- 2) To ensure constant heat emission
- 3) With MS 34 10x plugged in and M12 connectors/caps screwed into place

Table 4.1: General specifications



Notice!

The warm-up time before devices with integrated heating are ready for operation is approx. 30min. (depending on the environmental conditions).

For devices with integrated heating (...H models), window heating is in constant operation. Regulation of device-internal heating is temperature dependent.

4.2 Dimensioned drawings

BPS 34 SM 100 / BPS 34 SM 100 H / BPS 34 SM 100 HT

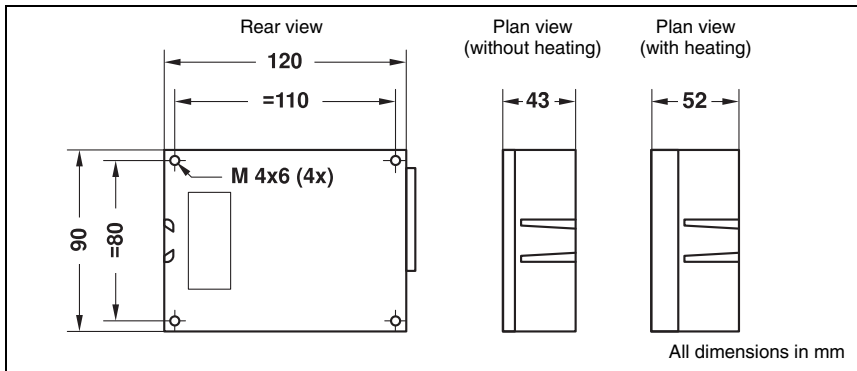

Figure 4.1: Dimensioned drawing BPS 34

MS 34 103 / MS 34 105

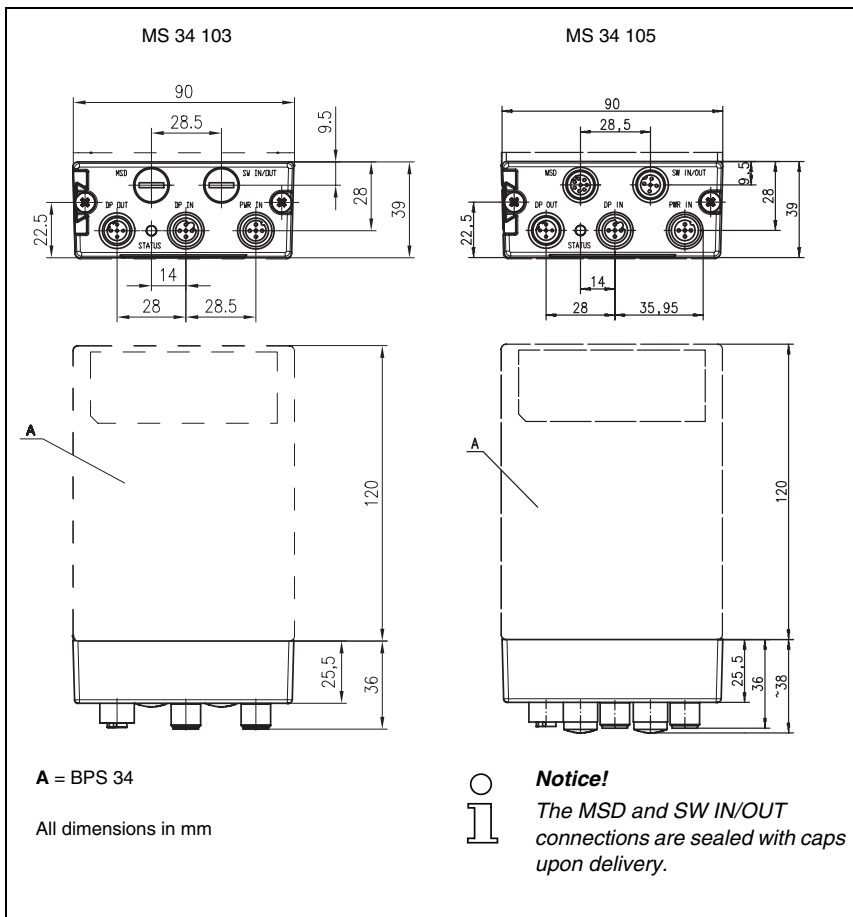

Figure 4.2: Dimensioned drawing MS 34 103 / MS 34 105

4.3 Electrical connection

The BPS 34 can be connected via the MS 34 103/MS 34 105 using M12 connectors. For the locations of the individual device connections, please refer to the device detail shown in figure 4.3.

The corresponding mating connectors and ready-made cables are available as accessories for all connections. For additional information, refer to chapter 10 starting on page 94.



Attention!

Connection of the device and cleaning must only be carried out by a qualified electrician.

If faults cannot be corrected, the device should be removed from operation and protected against possible use.

Before connecting the device, be sure that the supply voltage agrees with the value printed on the name plate.

The power supply unit for the generation of the supply voltage for the BPS 34 and the respective connection units must have a secure electrical insulation through double insulation and safety transformers according to EN 60742 (corresponds to IEC 60742).

Be sure that the protective conductor is connected correctly. Error-free operation is only guaranteed if the device is properly earthed.

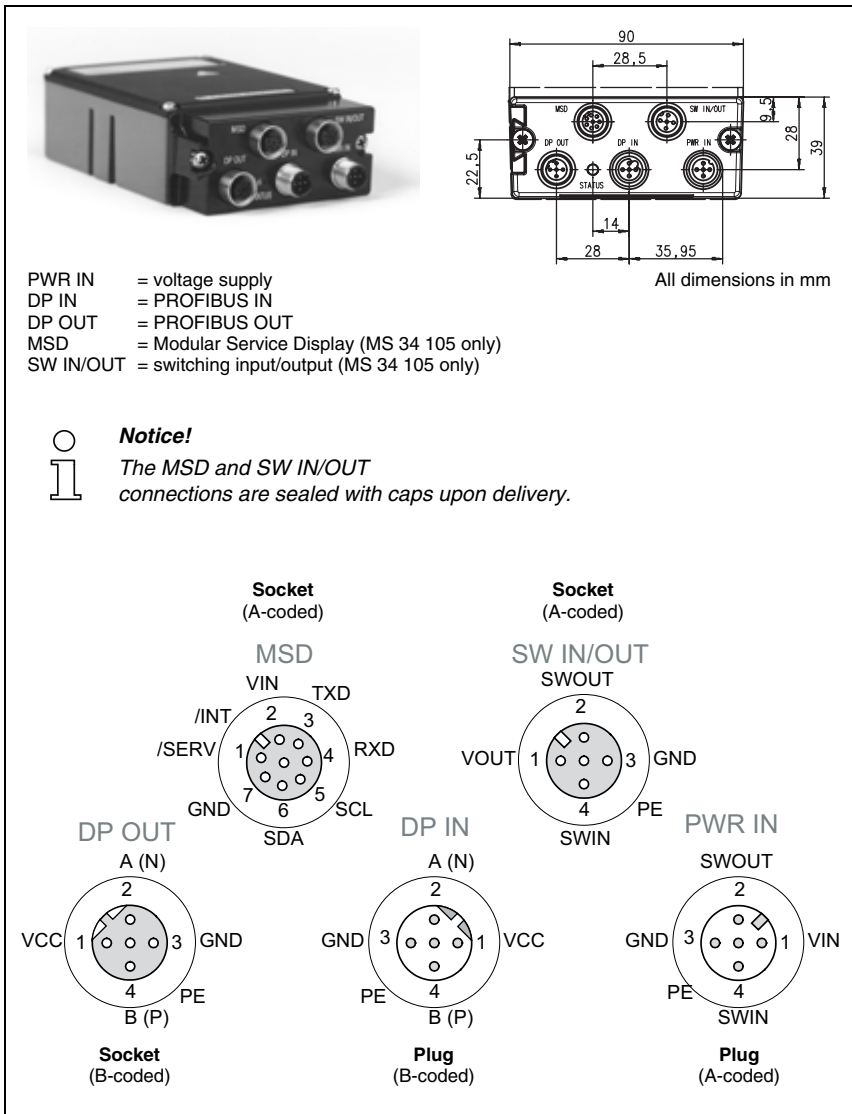

Figure 4.3: Connection assignment of the BPS 34 with MS 34 103 / MS 34 105



Attention!

Protection class IP 65 is achieved only if the connectors and caps are screwed into place!

4.3.1 PWR IN - voltage supply and switching input/output



Attention!

For devices with integrated heating, the supply voltage must be wired with a minimum 0.5mm² (recommended 0.75mm²) core cross section. It is not possible to loop the supply voltage through to other loads!



Notice!

Cables with a core cross section of 0.5mm² or 0.75mm² are not available as ready-made cables from Leuze electronic.

PWR IN (5-pin plug, A-coded)			
	Pin	Name	Remark
 <p>M12 plug (A-coded)</p>	1	VIN	Positive supply voltage without optics heating: +10 ... +30VDC with optics heating: +22 ... +26VDC
	2	SWOUT	Switching output
	3	GND	Negative supply voltage 0VDC
	4	SWIN	Switching input
	5	PE	Functional earth
	Thread	PE	Functional earth (housing)

Figure 4.4: Pin assignment PWR IN

Connection of the functional earth PE

BPS 34 including hood with integrated connectors MS 34 103/MS 34 105:

↳ Connect **PE** to **PIN 5 of the M12 connector PWR IN** for the voltage supply!

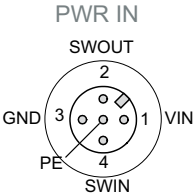

Notice!

Programming of the switching input/switching output is performed via module 7 (Switching input) and module 8 (Switching output). For further information, see also chapter 8.1.7.7, page 59 ff.



Notice!

The switching input/switching output of the **PWR IN** plug connection is identical to the **SWIN** switching input and **SWOUT** switching output of the **SW IN/OUT** plug connection on the MS 34 105.



Attention!

Protection class IP 65 is achieved only if the connectors and caps are screwed into place!

4.3.2 DP IN - PROFIBUS DP incoming

DP IN (5-pin plug, B-coded)			
 <p>DP IN</p> <p>A (N)</p> <p>2</p> <p>GND 3</p> <p>PE</p> <p>4</p> <p>B (P)</p> <p>VCC 1</p> <p>M12 plug (B-coded)</p>	Pin	Name	Remark
	1	VCC	5VDC for bus termination
	2	A (N)	Receive/transmit data A-line (N)
	3	GND	Functional earth for bus termination
	4	B (P)	Receive/transmit data B-line (P)
	5	PE	Functional earth
Thread	PE	Functional earth (housing)	

Figure 4.5: Pin assignment DP IN



Attention!

Protection class IP 65 is achieved only if the connectors and caps are screwed into place!

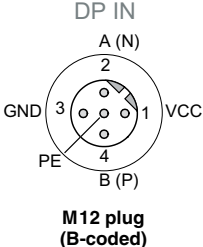
4.3.3 DP OUT - PROFIBUS DP outgoing

DPOUT (5-pin socket, B-coded)			
 <p>DP OUT</p> <p>A (N)</p> <p>2</p> <p>VCC 1</p> <p>GND 3</p> <p>PE</p> <p>4</p> <p>B (P)</p> <p>M12 socket (B-coded)</p>	Pin	Name	Remark
	1	VCC	5VDC for bus termination
	2	A (N)	Receive/transmit data A-line (N)
	3	GND	Functional earth for bus termination
	4	B (P)	Receive/transmit data B-line (P)
	5	PE	Functional earth
Thread	PE	Functional earth (housing)	

Figure 4.6: Pin assignment DP IN



Attention!

Protection class IP 65 is achieved only if the connectors and caps are screwed into place!

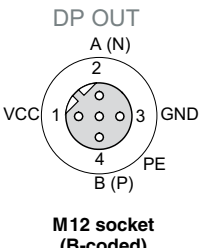

Notice!

If the PROFIBUS is not connected to another subscriber via the MS 34 10x, the DP OUT connection must be fitted with a TS 02-4-SA terminator plug for the purpose of bus termination. For further information, see also chapter 10.4 on page 94.

4.3.4 SW IN/OUT - switching input/switching output

SW IN/OUT (5-pin socket, A-coded)			
	Pin	Name	Remark
 <p>SW IN/OUT SWOUT</p> <p>VOUT 1 2 3 GND</p> <p>4 PE</p> <p>SWIN</p> <p>M 12 socket (A-coded)</p>	1	VOUT	Supply voltage for sensors (VOUT identical to VIN at PWR IN) without optics heating: +10 ... +30 VDC with optics heating: +22 ... +26 VDC
	2	SWOUT	Switching output
	3	GND	Supply voltage for sensors 0VDC
	4	SWIN	Switching input
	5	PE	Functional earth
	Thread	PE	Functional earth (housing)

Figure 4.7: Pin assignment SW IN/OUT



Attention!

Protection class IP 65 is achieved only if the connectors and caps are screwed into place!

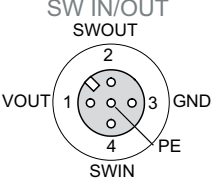

Notice!

Programming of the switching input/switching output is performed via module 7 (Switching input) and module 8 (Switching output). For further information, see also chapter 8.1.7.7, page 59 ff.



Notice!

The switching input/switching output of the **PWR IN** plug connection is identical to the **SWIN** switching input and **SWOUT** switching output of the **SW IN/OUT** plug connection on the MS 34 105.



Attention!

If you use a sensor with a standard M12 connector, then please note the following:

Only use sensors on which the switching output does not lie on pin 2, i.e. only sensor cables on which pin 2 is not assigned. Otherwise, the switching output is not protected against feedback on the switching input. If the inverted sensor output lies on pin 2, erroneous behaviour of the switching output will result!

Connecting the switching input / switching output

The BPS 34 is provided with a switching input and a switching output. The connection is performed as shown in figure 4.8:

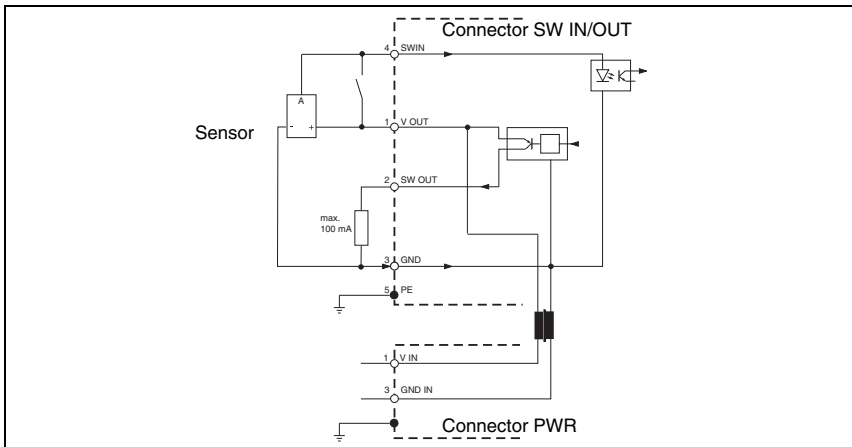

Figure 4.8: Connection of the switching input/output of the BPS 34

4.3.5 BPS 34 reading field curve

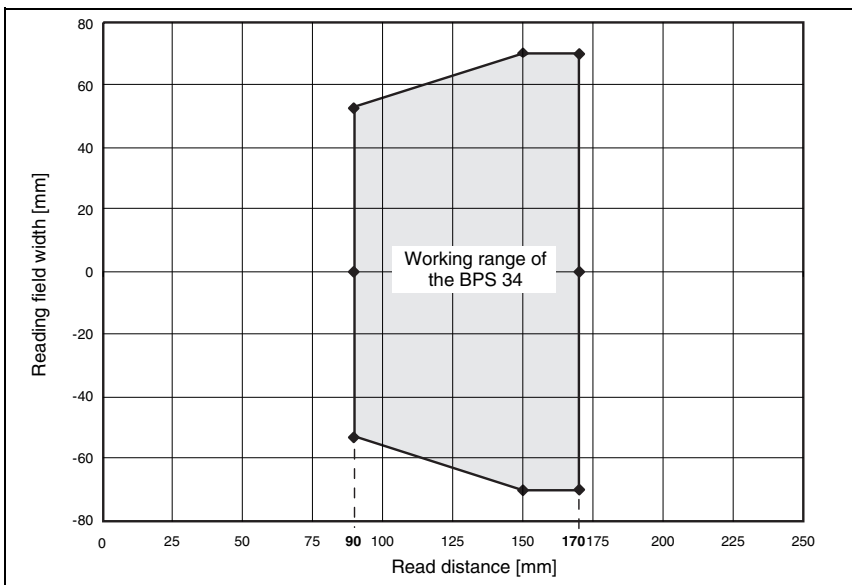

Figure 4.9: BPS 34 reading field curve

5 Connector units MS 34 ... / MSD 1 101

5.1 Modular hoods with integrated connectors MS 34 103 and MS 34 105

A modular hood of type MS 34 103 or MS 34 105 with integrated connectors is part of every BPS 34. The two hoods with integrated connectors are used to connect the BPS 34 to the PROFIBUS. For this, they feature one **DP IN** and one **DP OUT** connection each, as well as switches for address setting.

If only the connection to the PROFIBUS is intended, type MS 34 103 is sufficient.

If, in addition, switching input/output or a modular service display are to be connected, an MS 34 105 is required. Although switching input and output are available on the voltage supply connector PWR IN, the switching input of the MS 34 105 has the advantage that a standard sensor connector can be used.

5.1.1 General information

The modular hoods with integrated connectors are necessary accessories for connecting a BPS 34 in a PROFIBUS system. On the MS 34 10x, the PROFIBUS is connected, the PROFIBUS address set and the BPS 34 supplied with voltage.

MS 34 103

The MS 34 103 offers the following interfaces:

- PROFIBUS incoming **DP IN**
- PROFIBUS outgoing **DP OUT**
- Voltage supply **PWR IN** with switching input and switching output

MS 34 105

In addition to the MS 34 103, the MS 34 105 offers the following interfaces:

- for the modular service display **MSD**
- M12 connection for switching input and switching output **SW IN/OUT**

5.1.2 Specifications of the connector units

Mechanical data

Protection class	IP 65 ¹⁾
Weight	160 g
Dimensions (W x H x D)	38 x 90 x 39mm
Housing	diecast zinc

1) with M12 connectors/caps screwed into place

5.1.3 Dimensioned drawings

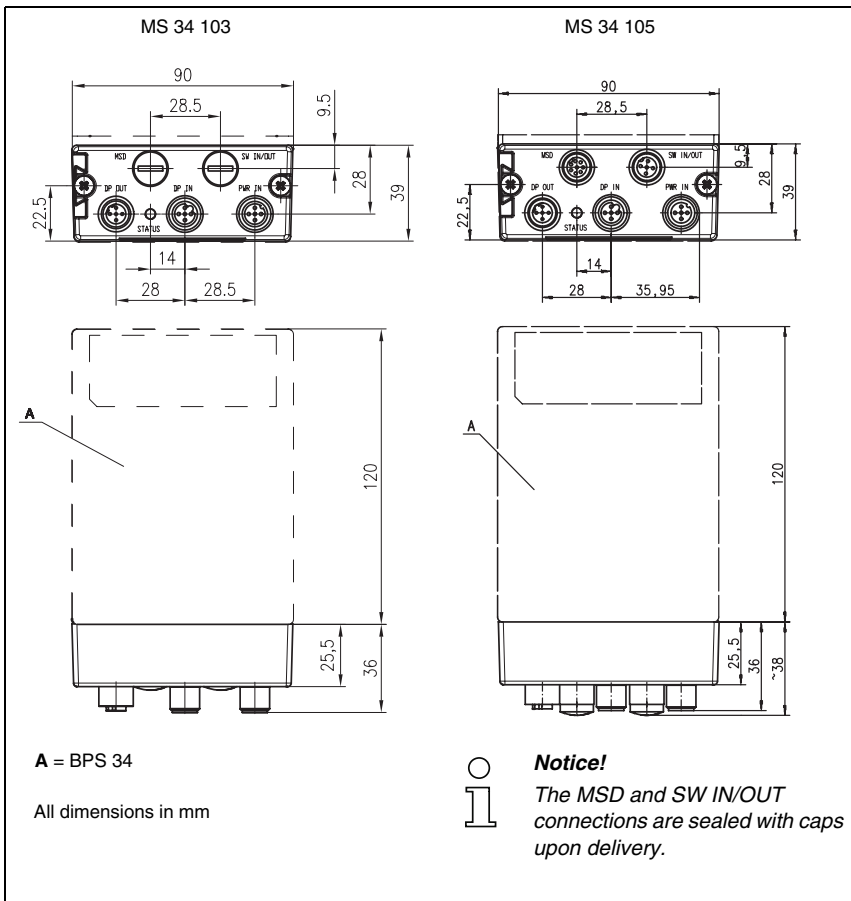

Figure 5.1: Dimensioned drawing MS 34 103 / MS 34 105

5.1.4 Electrical connection

Electrical data

Interface type	PROFIBUS DP, up to 12MBd
Service interface ¹⁾	RS232 with default data format, 9600Bd, 8 data bits, no parity, 1 stop bit
Switching input / output	1 switching input, 1 switching output, each is programmable
Operating voltage	without optics heating: 10 ... 30VDC with optics heating: 22 ... 26VDC
Power consumption	without optics heating: 5W with optics heating: max. 30W

1) Only in combination with the MS 34 105 and MSD 1 101 devices

5.1.5 Description of the LED states

MS 34 103 / MS 34 105

At the modular hood with integrated connectors a **status LED** is located between the M12 connectors DP IN and DP OUT. It indicates the state of the PROFIBUS connection.

State	Meaning
off	voltage off or device not yet recognised by the PROFIBUS ²⁾
green flashing	initialisation of the device, establishing the PROFIBUS communication
green, continuous light	data operation
red, flashing	error on the PROFIBUS, error can be resolved by a reset of the control
red, continuous light	error on the PROFIBUS, error cannot be resolved by a reset of the control
orange, continuous light	service operation active

2) Note: The LED remains off until the BPS 34 is recognised by the PROFIBUS. Only after the PROFIBUS has addressed the BPS 34 for the first time, the following status descriptions apply.

5.2 Modular Service Display MSD 1 101

5.2.1 General information

The modular service display is used to display the calculated positions and operational data on the one hand, and as simple access to the service interface on the other. The RS 232 service interface of the BPS 34 is located on the 9-pin sub-D connector of the MSD.

To connect the MSD 1 101 to the MS 34 105, an 8-pin cable (M12) with a length of 2m is used (see chapter 10.3 "Accessory modular service display").

Using the service display, new settings for the BPS 34 can be tried quickly and easily, without having to configure these settings via the PROFIBUS. The settings can be made via PC using the **BPS Configuration Tool**.

Once optimal settings for standard operation have been found, these must be configured in the PROFIBUS project in order for them to become permanently active.



Notice!

The BPS 34, in combination with the MS 34 10x, is equipped with an internal parameter memory in which all configured settings are stored. When switching back from maintenance mode to PROFIBUS mode, the settings specified in maintenance mode are overwritten by the settings stored in the control.



Attention!

If parameters are changed that can also be set via the PROFIBUS, they are overwritten with the parameter setting defined in the PROFIBUS project after PROFIBUS start-up. If device or module parameters are to be changed permanently, they must be set in the PROFIBUS project.

5.2.2 Dimensioned drawing

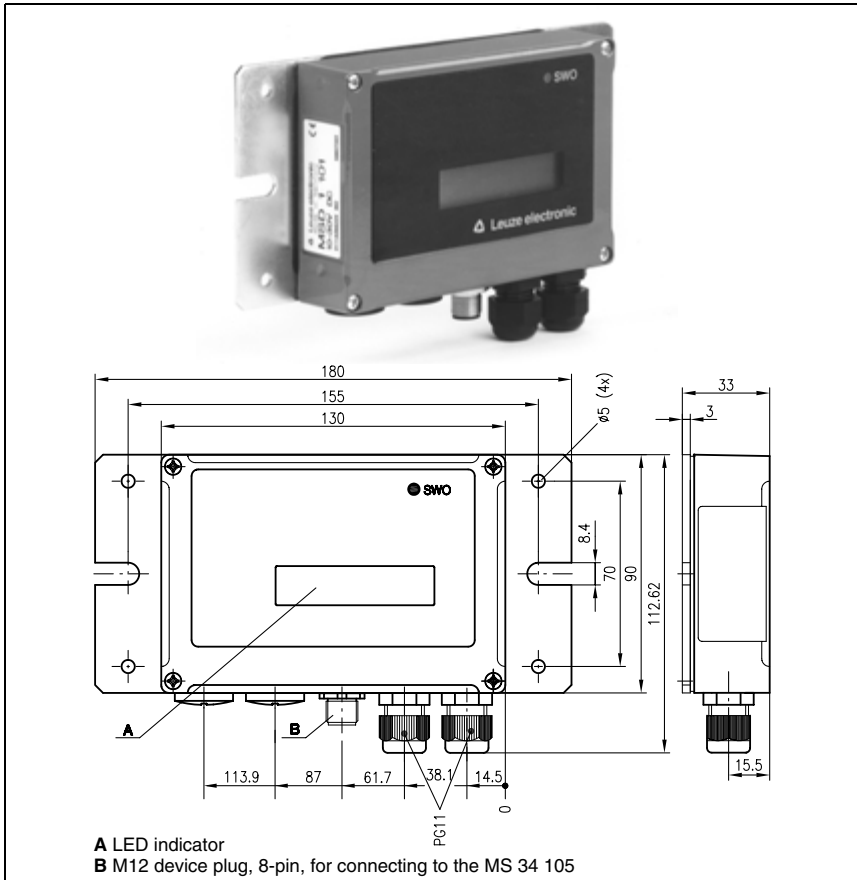

Figure 5.2: Modular Service Display MSD 1 101

5.2.3 Electrical connection

MSD 1 101

The connection between the MSD 1 101 and the MS 34 105 is established via the pre-configured cable KB 034 2000. The service interface for connecting a PC is located inside the MSD 1 101 and is designed as a 9-pin sub-D connector. The pin configuration of the 9-pin sub-D connector corresponds to a standard RS 232 interface:

- PIN 2 = RxD
- PIN 3 = TxD
- PIN 5 = GND

6 Barcode tape

6.1 General information

The barcode tape (BCT) is delivered on a roll. A roll contains up to 200m of BCT, with the wrapping direction from the outside to the inside (smallest number on the outside). If a BCT is ordered which is considerably longer than 200m, the total length is divided into rolls of 200m each (see chapter 10.9 "Type overview: Barcode tape" on page 98).



Figure 6.1: Roll with barcode tape

Features:

- Robust and durable polyester adhesive tape
- High dimensional stability
- Max. length 10'000m
- Self-adhesive, high adhesive strength

6.2 Specifications of the barcode tape

Dimensions

Standard height	47 mm (other heights on request)
Length	0 ... 5m, 0 ... 10m, 0 ... 20m, ..., 0 ... 150m, 0 ... 200m, special lengths and special codings for lengths from 150m, for details see order guide in chapter 10.9, page 98

Construction

Manufacturing process	Filmsetting
Surface protection	Polyester, matt
Base material	Polyester film, affixed without silicone
Adhesive	Acrylate adhesive
Adhesive thickness	0.1 mm
Adhesive strength (average values)	on aluminium: 25N/25mm on steel: 25N/25mm on polycarbonate: 22N/25mm on polypropylene: 20N/25mm

Environmental data

Recom. processing temperature	0°C ... +45°C
Temperature resistance	-40°C ... +120°C
Dimensional stability	no shrinkage, tested according to DIN 30646
Curing	final curing after 72h, the position can be detected immediately by the BPS 34 after the BCT is affixed
Thermal expansion	due to the high elasticity of the BCT, thermal expansion of the base material on which the BCT is affixed is not known to have an effect
Tearing resistance	150N
Elongation at tear	min. 80%, tested in accordance with DIN 50014, DIN 51220
Weathering resistance	UV-light, humidity, salt spray (150h/5%)
Chemical resistance (tested at 23°C for 24h)	transformer oil, diesel oil, white spirit, heptane, ethylene glycol (1:1)
Behaviour in fire	self-extinguishing after 15s, does not drip
Mounting surface	grease-free, dry, clean, smooth

Table 6.1: Specifications of the barcode tape

6.3 Mounting the barcode tape

To prevent deposits of dirt from forming, it is recommended that the BCT be affixed vertically, possibly with a roof-like cover. If the application does not permit this, permanent cleaning of the BCT by on-board cleaning devices such as brushes or sponges is not permitted in any case. Permanent on-board cleaning devices polish the BCT and give it a glossy finish. The read quality deteriorates as a result.



Notice!

When mounting the BCT, it must be ensured that neither strong sources of extraneous light nor reflections of the base on which the BCT is affixed occur in the area of the scanning beam.

The recommended interruption points on the BCT are at the provided cut marks.

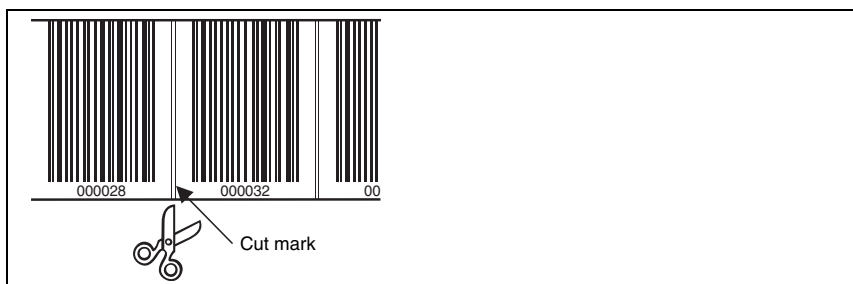

Figure 6.2: Cut mark on the barcode tape



Notice!

Cutting the BCT and affixing the tape so that a gap forms which is so large that a label can no longer be reliably detected in the scanning beam results in double positions during the position calculation of the BPS. The gap must not be greater than the distance from one cut mark to the next (max. one label).

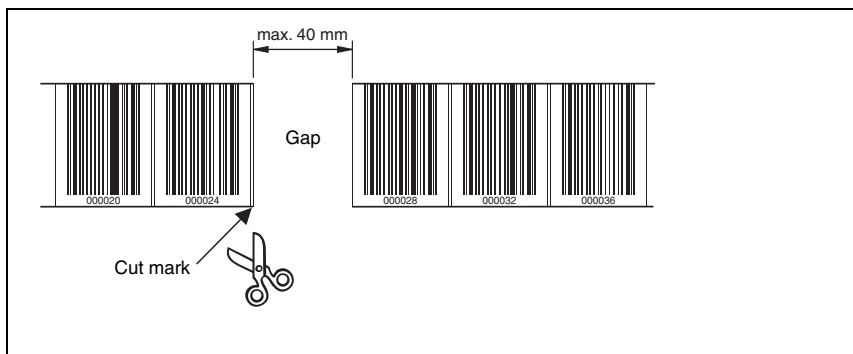

Figure 6.3: Gap in the cut barcode tape

Procedure:

- Examine the mounting surface. It must be flat, without warping, free of grease and dust, and dry.
- Define a reference edge (e.g. metal edge of the busbar)
- Remove the backing and affix the BCT along the reference edge **tension free**. Secure the BCT to the mounting surface by pressing down with the palm of your hand. When affixing, make certain that the BCT is free of folds and creases and that no air pockets form.
- Never pull the BCT. Because this is a plastic tape, forceful pulling may stretch it. This results in a distortion of the measurement units on the tape. While the BPS 34 can still perform the position calculation, the accuracy in this case is no longer ensured. If the values are taught using a teach-in process, distortions are irrelevant.
- Expansion joints with widths up to several millimetres can simply be covered with the barcode tape. The tape must not be interrupted at this location.
- Protruding screw heads can simply be taped over. Cut out the bar code which covers the screw head at the cut marks.
- If the application dictates the necessity of a gap, the tape is to be affixed over this gap and the affected cut marks cut out. If the gap is small enough that the scanning beam can detect the label to the left or to the right of the gap, measurement values are delivered without interruption. If the scanning beam cannot completely scan any label, the BPS 34 returns the value 0. As soon as the BPS 34 can again scan a complete label, it calculates the next position value.
- The maximum gap between two barcode positions without affecting the measurement value is 40mm.

**Notice!**

If the barcode tape was damaged, e.g. by falling parts, a repair kit can be downloaded from the Internet (www.leuze.de -> Under the heading Download -> Logistics -> Optical barcode positioning -> Repair Kit for Barcode Tape).

**Notice!**

*You can also view a video which illustrates how to affix the barcode tape on the Internet at www.leuze.de -> **Download -> Logistics -> Optical barcode positioning -> Videos -> How to mount BPS 34/37.***

**Attention!**

Barcode tapes with different value ranges may not directly follow one another. If the value ranges are different, the gap between the two BCTs must be greater than the detection range of the scanning beam or control barcodes must be used (for further information see chapter 6.4 on page 32).

**Notice!**

When working with the BCT in cold warehouses, it should be ensured that the BCT be affixed before the warehouse is cooled. However, if it should be necessary to work with the BCT at temperatures outside of the specified processing temperature, please make certain that the bonding surface as well as the BCT are at the processing temperature.



Notice!

When working with BCT in curves, the BCT should only be partially cut at the cut mark and affixed along the curve like a fan; it must also be ensured that the BCT is affixed without tension (see figure 6.3).

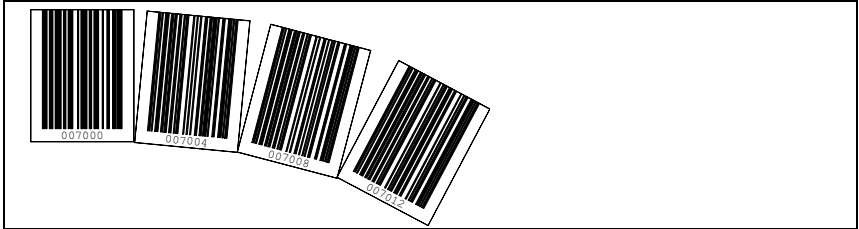

Figure 6.4: Partial cutting of the barcode tape in curves

6.4 Control barcode

With the aid of control barcodes, which are simply affixed over the barcode tape at the necessary locations, functions can be activated and deactivated in the BPS 34.



Notice!

The control of functions using control barcodes is a new feature of the BPS 34. The implementation of additional control options via control barcodes is in preparation.

Structure of the control barcode

The control barcodes utilise code type Code128 with character set B; the position barcodes, on the other hand, utilise Code128 with character set C. Code 128 with character set B enables the display of all letters and numbers in the ASCII character set.

System arrangement

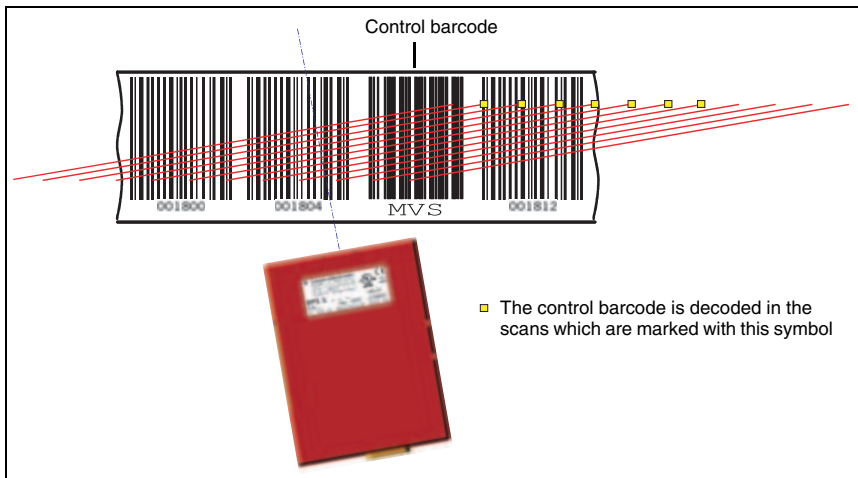

Figure 6.5: System arrangement of control barcodes

The control barcode is affixed either within one or between two barcode tapes in such a way that one position barcode is replaced or two barcode tapes are seamlessly connected to one another.



Attention!

It must be ensured that only one control barcode is located in the scanning beam at any one time. Thus, the minimum distance between two control barcodes is determined by the distance between the BPS and barcode tape and the resulting length of the scanning beam.

For error-free function, when using control barcodes it must absolutely be ensured that the distance between the BPS and barcode tape is selected large enough. The scanning beam of the BPS should cover three or more barcodes; this is ensured at a distance which lies in the working range of the reading field curve.

The control barcodes are simply affixed over the existing tape. When affixing the control barcodes, make certain to cover entire barcodes to ensure that a barcode spacing of 4cm is maintained.

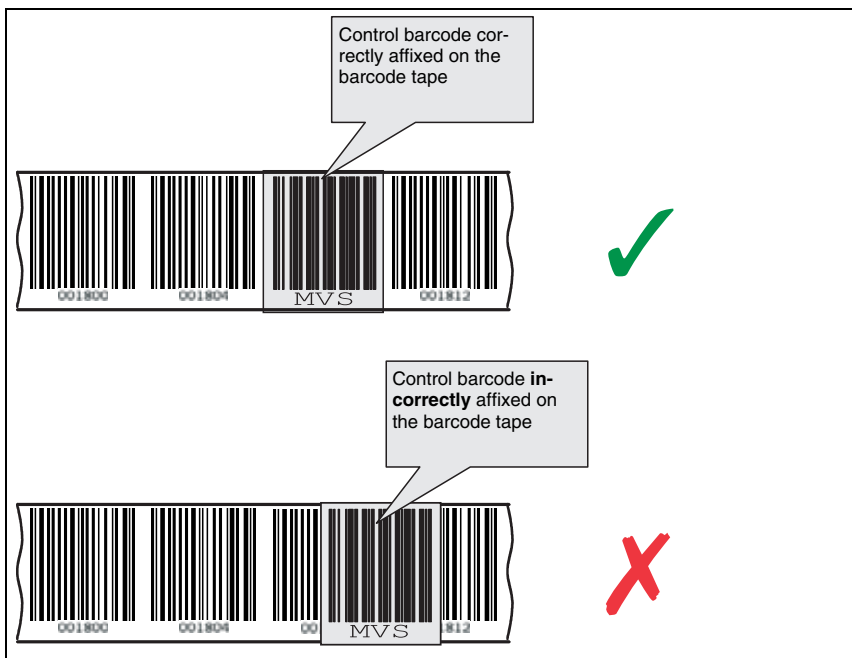

Figure 6.6: Correct positioning of the control barcode

6.4.1 Controllable functions

Measurement value switching between 2 barcode tapes with different value ranges

The "MVS" control barcode is used to switch between two barcode tapes. The end of one tape and the start of the next can end and begin, respectively, with completely different position barcodes. If the centre of the BPS 34 reaches the transition point of the control barcode, the device switches to the second tape, provided the next position label is in its scanning beam. As a result, the output position can always be uniquely associated with one tape.

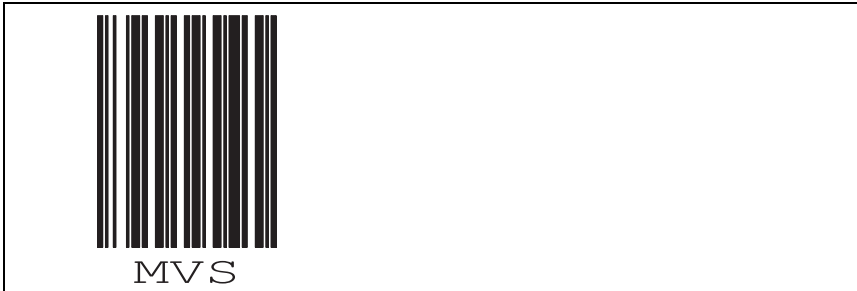

Figure 6.7: "MVS" control barcode for switching between tapes

Use of the "MVS" control barcode for switching between tapes is not dependent on direction. This means that it functions for switching from tape 1 to tape 2 and vice versa.

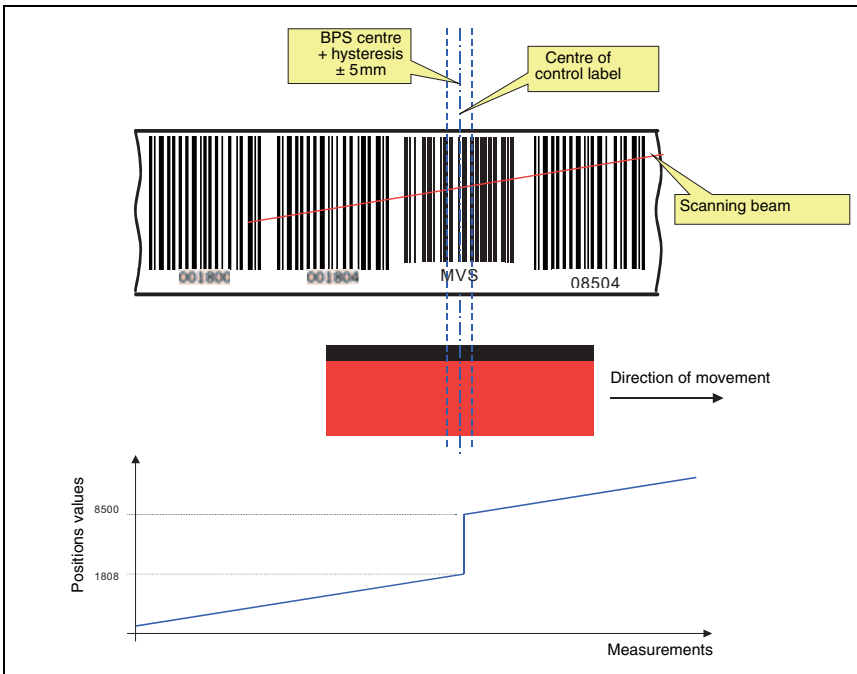

Figure 6.8: Switching position with the "MVS" control barcode

If the "MVS" label is passed over, the new tape value is always output relative to the centre of the device or label (see figure 6.8). In this situation, the hysteresis of $\pm 5\text{mm}$ is irrelevant.

If, however, the device is stopped within the hysteresis on the "MVS" label and the direction changed, the starting position values have an inaccuracy $\pm 5\text{mm}$.

**Notice!**

When affixing the BCT in a system in which the end of one BCT meets the start of another BCT (position value X with position value 0), ensure that position labels $0 - 20$ are not used. This means that position label 24 must be the first label used on the continuing barcode tape.

**Notice!**

If only the "MVS" label is read within the scanning beam, the scanning beam must not be interrupted during the read operation until the scanner can again read a complete position label.

If only the "MVS" label is located in the scanning beam, the voltage on the BPS 34 must not be switched off. Otherwise the BPS 34 will return a position value of zero when the voltage is switched back on.

Moreover, the scanner must not be configured while in this position. Otherwise, a value of zero is output as long as no position label is present in the scanning beam due to the fact that the scanning beam is switched off during configuration.

6.5 Repair kit

**Notice!**

If the barcode tape was damaged, e.g. by falling parts, a repair kit can be downloaded from the Internet (www.leuze.de -> Under the heading Download -> Logistics -> Optical barcode positioning -> Repair Kit for Barcode Tape).

In these 4 files you will find all code information for a tape with lengths of $0 \dots 500\text{m}$, $500 \dots 1000\text{m}$, $1000 \dots 1500\text{m}$ and $1500 \dots 2000\text{m}$. 1m of barcode tape is provided on each A4 sheet. Each metre is divided into 5 lines of 20cm, each with 5 code segments of information covering lengths of 4cm each.

Procedure when replacing the defective area:

1. Determine the coding of the defective area.
2. Print out the area determined to be defective
3. Affix the printed area over the defective location

Important note for printing:

1. Select only those pages that are actually required.
2. Change the printer settings so that the code is not distorted.
Suggestion for printer settings, see figure 6.9.
3. Verify the printing result by measuring the distance between two codes (see figure 6.10).
4. Cut the code strips and concatenate them. It is important that the code content always increases or decreases in blocks of 4 cm.

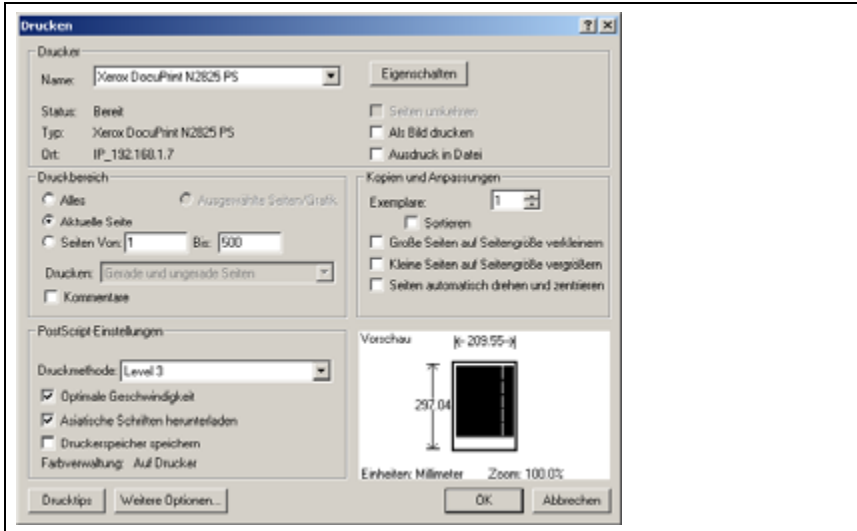

Figure 6.9: Printer settings for BCT repair kit

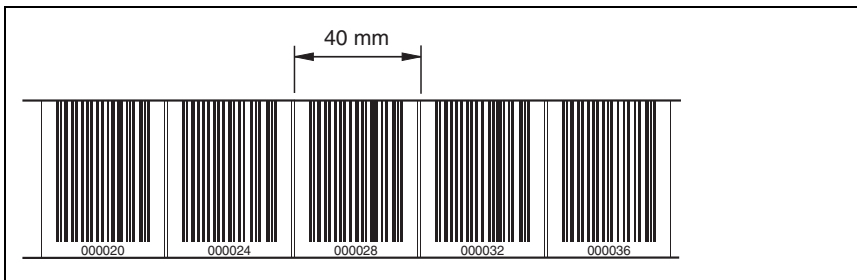

Figure 6.10: Checking the print results of the BCT repair kit

7 Mounting

7.1 Mounting the BPS 34

There are two different types of mounting arrangements for the BPS 34:

- Using 4 M4x6 screws on the rear of the device.
- Using the BT 56 mounting device on the fastening grooves.

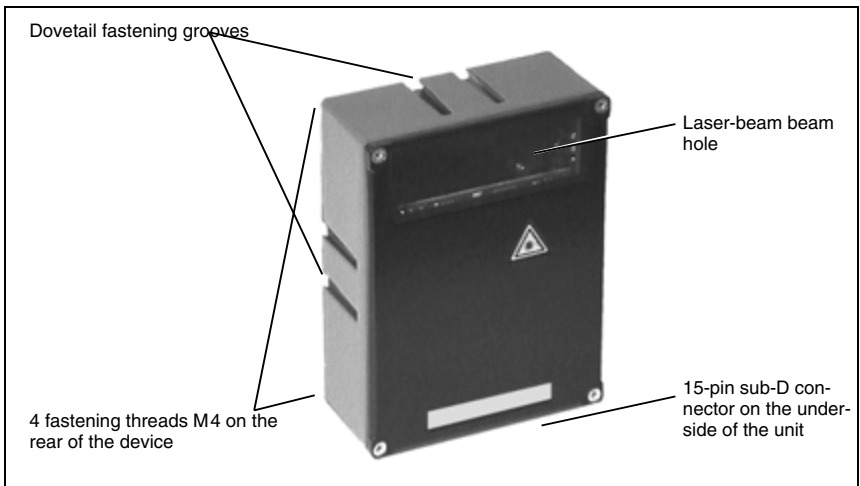

Figure 7.1: BPS 34 mounting options

BT 56 mounting device

The BT 56 mounting device is available for mounting the BPS 34 using the fastening grooves. It is designed for rod installation (\varnothing 16mm to 20mm). For ordering instructions, please refer to chapter 10.6 on page 94.

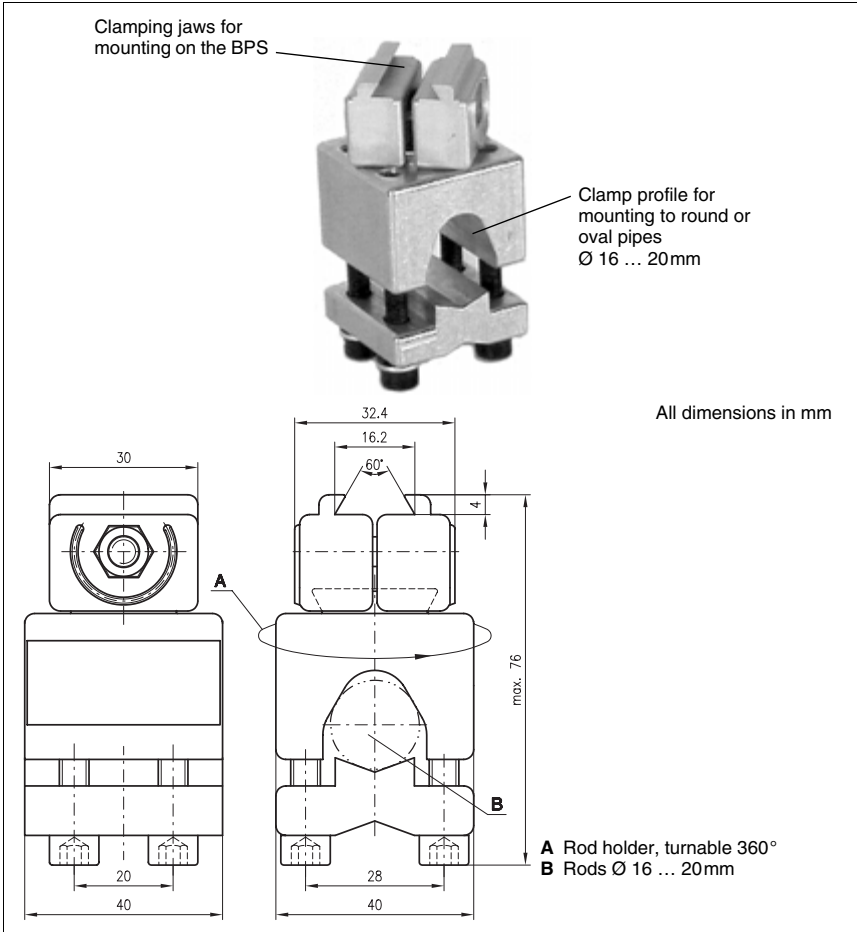

Figure 7.2: BT 56 mounting device

Mounting example BPS 34

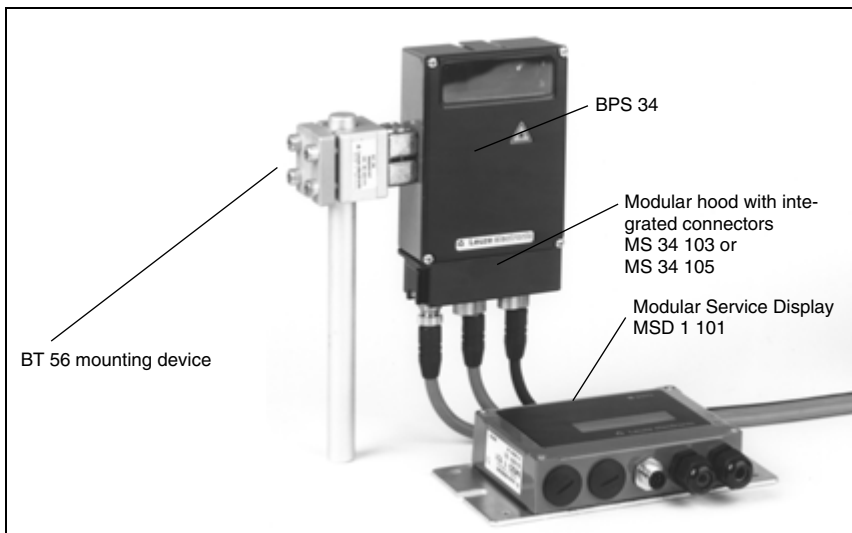

Figure 7.3: Mounting example BPS 34



Notice!

During mounting, the following angles of inclination must be taken into account in the vertical axis:

10° for a tape height of 47mm,

7° for a tape height of 30mm and

5° for a tape height of 25mm; the working range of the reading field curve must also be taken into account.



Attention!

For the position calculation, the scanning beam of the BPS 34 must be incident on the barcode tape without interruption. Ensure that the scanning beam is always incident on the barcode tape when the system is moving.

7.2 Device arrangement

Selecting a mounting location

In order to select the right mounting location, several factors must be considered:

- The scanning range determined from the scanning curve must be adhered to at all locations where a position determination is to be made
- The BPS should be mounted at an angle of 10° (depending on the tape height, see notice page 39) in the vertical axis relative to the barcode tape to ensure continued reliable positioning results even in the event of soiling of the barcode tape.
- On the BPS 34, the beam is not emitted perpendicular to the cover of the housing, but with an angle of 10° towards the top. This angle is intended to prevent total reflection on the barcode tape. This beam exit is already integrated in the device. As a result, the BPS can be at the minimum read distance and mounted parallel to the barcode tape.

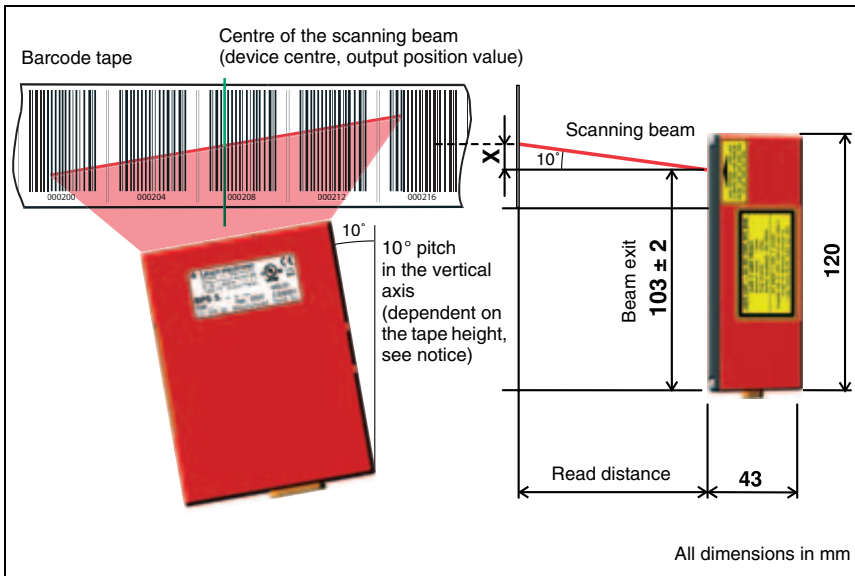

Figure 7.4: Beam exit and device arrangement of the BPS 34

Dimension **X** in figure 7.4 shows the mounting height of the BCT centre relative to the housing of the BPS 34. Dimension **X** is dependent on the read distance. Please refer to the following table for the value:

Read distance [mm]	Dimension X [mm]	Read distance [mm]	Dimension X [mm]	Read distance [mm]	Dimension X [mm]
90	16	120	21	150	26
100	18	130	23	160	28
110	19	140	25	170	30

**Notice!**

The best functionality is obtained when:

- the BPS is guided parallel to the tape.
- the permitted working range is not exited.

Mounting location

👉 *When selecting a mounting location, pay attention to*

- maintaining the required environmental conditions (humidity, temperature),
- possible soiling of the reading window due to liquids, abrasion by boxes, or packaging material residues.

Mounting outdoors/devices with integrated heating

When mounting outdoors or for devices with integrated heating, also observe the following points:

- mount the BPS 34 in a way which provides maximum thermal isolation, e.g. using rubber-bonded metal.
- mount in such a way that the device is protected from relative wind; mount additional shields if necessary.

**Notice!**

When installing the BPS 34 in a protective housing, it must be ensured that the scanning beam can exit the protective housing without obstruction.

7.3 Mounting the barcode tape

The BPS 34 and barcode tape combination is mounted in such a way that the scanning beam is unobstructed and is incident on the barcode tape as described in figure 7.4 on page 40.

Notice!

For further information on mounting the barcode tape, please refer to chapter 6.3 on page 29.

8 Device parameters and interfaces

8.1 PROFIBUS

8.1.1 General information

The BPS 34 with MS 34 103/MS 34 105 is designed as a PROFIBUS device (PROFIBUS DP-V0 acc. to IEC 61784-1) with a baud rate of 12MBd. The functionality of the device is defined via parameter sets which are clustered in modules. These modules are contained in a GSE file. The **GSE file** can be downloaded from the Leuze Homepage at www.leuze.de -> **under the heading Download -> Logistics -> Optical barcode positioning**. By using a user-specific project tool, such as, e.g., Simatic Manager for the Siemens programmable logic control, the required modules are integrated into a project during commissioning and its settings and parameters are adjusted accordingly. These modules are provided by the GSE file.

All input and output modules described in this documentation are described from the controller's perspective:

- Input data arrives at the controller
- Output data are sent out by the controller.

8.1.2 Electrical connection

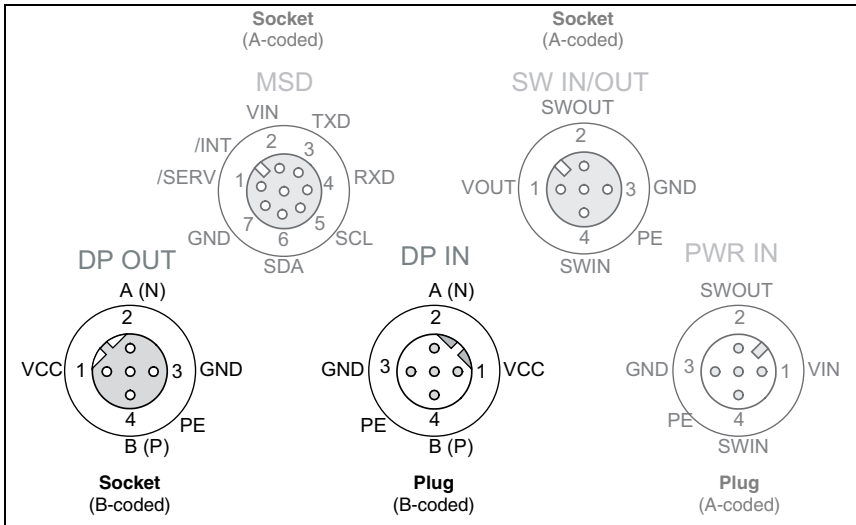

Figure 8.1: Electrical connection of PROFIBUS connections DP IN and DP OUT

DP IN - PROFIBUS DP incoming

DP IN (5-pin plug, B-coded)			
<p>DP IN</p> <p>A (N)</p> <p>2</p> <p>3 GND 1 VCC</p> <p>4 B (P)</p> <p>PE</p> <p>M12 plug (B-coded)</p>	Pin	Name	Remark
	1	VCC	5VDC for bus termination
	2	A (N)	Receive/transmit data A-line (N)
	3	GND	Functional earth for bus termination
	4	B (P)	Receive/transmit data B-line (P)
	5	PE	Functional earth
Thread	PE	Functional earth (housing)	

Figure 8.2: Pin assignment DP IN

DP OUT - PROFIBUS DP outgoing

DPOUT (5-pin socket, B-coded)			
<p>DP OUT</p> <p>A (N)</p> <p>2</p> <p>1 VCC 3 GND</p> <p>4 B (P)</p> <p>PE</p> <p>M12 socket (B-coded)</p>	Pin	Name	Remark
	1	VCC	5VDC for bus termination
	2	A (N)	Receive/transmit data A-line (N)
	3	GND	Functional earth for bus termination
	4	B (P)	Receive/transmit data B-line (P)
	5	PE	Functional earth
Thread	PE	Functional earth (housing)	

Figure 8.3: Pin assignment DP IN



Attention!

Protection class IP 65 is achieved only if the connectors and caps are screwed into place!

**Notice!**

For connecting DP IN and DP OUT, we recommend our ready-made PROFIBUS cables. For further information, see chapter 10.8 on page 96.

The BPS 34 can be used in combination with an MS 34 103/MS 34 105 to branch out the PROFIBUS network. The continuing network is connected via DP OUT.

If the PROFIBUS is not connected to another subscriber via the MS 34 10x, the DP OUT connection must be fitted with a TS 02-4-SA terminator plug for the purpose of bus termination. For further information, see also chapter 10.4 on page 94.

**Attention!**

Never open the device yourself, as this may compromise protection class IP 65.

Before connecting the device, be sure that the supply voltage agrees with the value printed on the name plate.

Connection of the device and cleaning must only be carried out by a qualified electrician.

The power supply unit for the generation of the supply voltage for the BPS 34 and the respective connection units must have a secure electrical insulation through double insulation and safety transformers according to EN 60742 (corresponds to IEC 60742).

Be sure that the earthing conductor is connected correctly. Error-free operation is only guaranteed if the device is properly earthed.

If faults cannot be corrected, the device should be removed from operation and protected against possible use.

To then further isolate the error, proceed as described in chapter 9 on page 92.

8.1.3 PROFIBUS address

In the modular hoods with integrated connectors MS 34 103 and MS 34 105, the PROFIBUS address can be set via two rotary switches and one slide switch.

The configuration and function of the address switches is shown in figure 8.4.

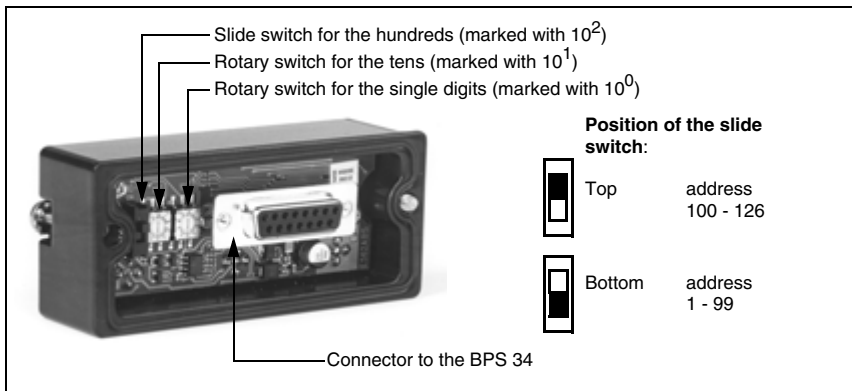

Figure 8.4: Setting the PROFIBUS address in the MS 34 103/MS 34 105

8.1.4 General information on the GSE file

You can find the GSE file at www.leuze.de -> **Download** -> **Logistics** -> **Optical barcode positioning**.

This file stores all the data required for the operation of the BPS 34. This data consists of device parameters required for operation of the BPS 34 and the definition of the control and status bits. If parameters are changed in the project tool, for example, these changes are stored in the project, not in the GSE file.

The GSE file is part of the device and must not be changed manually. The file is not changed by the system either.

If the BPS 34 is operated in a PROFIBUS network, configuration must be performed exclusively via the PROFIBUS. The functionality of the BPS 34 is defined via GSE parameter sets. The parameters and their functions are structured in the GSE file using module. A user-specific configuration tool is used during PLC program creation to integrate the required modules and configure them appropriately for their respective use.

During operation of the BPS 34 on the PROFIBUS, all parameters are set to default values. If these parameters are not changed by the user, the device functions with the default settings delivered by Leuze electronic. For the default settings of the BPS 34, please refer to the following module descriptions.



Notice!

A least one module in the GSE file must be activated in the configuration tool for the control, usually the "Position value" module 1.

**Notice!**

Some controls make available a so-called "universal module". This module must **not** be activated for the laser.

**Attention!**

The BPS 34 does not permanently store parameters changed via the PROFIBUS. Following Power off/on, the currently configured parameters are downloaded from the PROFIBUS manager. If no PROFIBUS manager is available following Power OFF/ON, the BPS 34 activates its stored default settings.

8.1.5 Structure of the GSE modules

In the current version, a total of 27 modules are available for use. The modules may be included into the project according to requirements and application.

The modules fall into the following categories:

- Parameter module for the configuration of the BPS 34.
- Status or control modules that influence the input/output data.
- Modules that may include both parameters and control or status information.

**Notice!**

All **input and output modules** described in this documentation are described **from the controller's perspective**.

Described inputs (I) are inputs in the control.

Described outputs (O) are outputs in the control.

Described parameters (P) are parameters of the GSE file in the control.

**Notice!**

At least one module must be activated to permit operation of the device at the PROFIBUS DP.

**Notice!**

Under some circumstances, not all 27 modules can be activated simultaneously in the configuration tool. Otherwise, the available memory for a subscriber may be exceeded. The maximum available memory for a device is control dependent.

8.1.6 Overview of the GSE modules



Notice!

Inputs and outputs are described from the perspective of the PROFIBUS master.

Module Page	Module name	Module contents (P) = Parameter, (O) = Output, (I) = Input
M1 page 51	Position value	(P) Sign
		(I) Position value
M2 page 52	Resolution	(P) Resolution for the position value
M3 page 53	Static preset	(P) Preset value added to tape value
		(O) Preset teach
		(O) Preset reset
M4 page 55	Dynamic preset	(O) Preset teach
		(O) Preset reset
		(O) Preset value
M5 page 56	Offset value	(P) Offset value
M6 page 57	Scaling	(P) Scaling factor
M7 page 59	Switching input	(P) Inversion
		(P) Mode
		(P) Debounce time
		(P) Start-up delay
		(P) Pulse duration
		(P) Switch-off delay
		(P) Function
(I) State		
M8 page 61	Switching output	(P) DC bias level
		(P) Selection of the velocity limit value
		(P) Pulse duration
		(P) Switch-on function
		(P) Switch-off function
M9 page 63	Control	(O) Switching output "PROFIBUS edge"
		(P) Measurement start mode
		(P) Measurement stop mode
		(P) Stop timeout
		(I) Status of position controller
		(O) Start event
M10 page 65	Measurement value acquisition	(O) Stop event
		(O) BPS standby
M11 page 66	Measurement value preparation	(P) Maximum permitted measurement length
		(P) Minimum permitted measurement length
M11 page 66	Measurement value preparation	(P) Integration depth
		(O) Count direction for position calculation

Module Page	Module name	Module contents (P) = Parameter, (O) = Output, (I) = Input
M12 page 68	Status	(I) Measurement error
		(I) Range status (outside of measurement range)
		(I) Preset active
		(I) Dynamic preset teach
		(I) State
		(I) Position limit value status 1
		(I) Position limit value status 2
		(I) Standby status
M13 page 69	Min/Max position	(P) Min/Max mode
		(P) Min/Max duration
		(I) Min position
		(I) Max position
M14 page 71	Static position limit value 1	(O) Min/Max reset
		(P) Limit value checking on/off
		(P) Switching mode (value is above or below the defined limits)
		(P) Hysteresis
M15 page 72	Static position limit value 2	(P) Limit value
		(P) Limit value checking on/off
		(P) Switching mode (value is above or below the defined limits)
		(P) Hysteresis
M16 page 73	Dynamic position limit value 1	(P) Limit value
		(P) Limit value checking on/off
		(P) Switching mode (value is above or below the defined limits)
		(P) Hysteresis
M17 page 74	Dynamic position limit value 2	(O) Limit value
		(P) Limit value checking on/off
		(P) Switching mode (value is above or below the defined limits)
		(P) Hysteresis
M18 page 75	Measuring error tolerance	(P) Position tolerance time
		(P) Error output delay
M19 page 76	Service	(I) Status
		(O) Reset to factory settings
M20 page 77	Velocity	(I) Current velocity
M21 page 78	Velocity parameters	(P) Resolution
		(P) Scaling factor
		(P) Integration depth
		(P) Tolerance time (on error message)
		(P) Error output delay

Module Page	Module name	Module contents (P) = Parameter, (O) = Output, (I) = Input
M22 page 80	Control velocity measurement	(P) Start mode of velocity measurement
		(P) Velocity measurement stop mode
		(I) Velocity measurement status
		(O) Start event
		(O) Stop event
		(O) Min/Max velocity mode
		(O) Min/Max velocity reset
M23 page 82	Status velocity measurement	(I) Measurement error
		(I) Limit value status 1 exceeded
		(I) Limit value status 2 exceeded
		(I) Limit value status 3 exceeded
		(I) Limit value status 4 exceeded
		(I) Dynamic limit value status exceeded
		(I) Movement status
		(I) Direction of movement
		(I) Compare limit value status 1
		(I) Compare limit value status 2
		(I) Compare limit value status 3
		(I) Compare limit value status 4
		(I) Compare dynamic limit value status
M24 page 84	Min/Max velocity	(I) Minimum velocity
		(I) Maximum velocity
M25 page 85	Static velocity limit values (for limit value 1 ... 4)	(P) Velocity limit value mode (active/not active)
		(P) Direction selection (both directions or only one)
		(P) Switching mode (value is above or below the defined limits)
		(P) Velocity limit value
		(P) Hysteresis
		(P) Range start
		(P) Range end
M26 page 88	Dynamic velocity limit values	(O) Limit value control
		(O) Switching mode (value is above or below the defined limits)
		(O) Direction selection
		(O) Limit value
		(O) Hysteresis
		(O) Range start
		(O) Range end
M27 page 90	Tape value correction	(P) Actual length
		(P) Range start
		(P) Range end

Table 8.1: Overview of the GSE modules

8.1.7 Detailed description of the modules

**Notice!**

In the following detailed descriptions of the modules, you will find in the last column of the tables **cross references (CR) to parameters and input/output data of other modules** which are directly related to the described parameter. These cross references must be observed during configuration.

The individual **modules** are **numerically** labelled from **1 ... 27**.

The **parameters and input/output data** within a module are **alphanumerically** labelled from **a ... z**.

Example:

The **a Static preset value in [mm]** parameter in module 3 becomes active only when the preset teach occurs via module 12 **c**, 7 **g** or 3 **b**.

8.1.7.1 Module 1: Position value

Description:

With this module, the current position value is output.



Notice!

The position value is the position value calculated from the tape value and the settings for resolution, preset and offset.

Parameter

Parameter	Description	Rel. addr.	Data type	Value range	Default	Unit	CR to module
^a Sign	Output mode for sign.	0	unsign 8	0: Two's complement 1: Sign + magnitude	0	–	–
Parameter length: 1 byte							

Hex coding of module 1 "Position value"

The value listed in the table shows the hex coding of the default settings.

Internal address of module 1	Sign
13	00

Input data

Input data	Description	Rel. addr.	Data type	Value range	Default	Unit	CR to module
^b Position value	Output of the current position.	0	sign 32	-10'000'000 ... +10'000'000 (for a resolution in mm)	0	scaled	–
Input data length: 4 byte							



Notice!

A negative number is represented in the input data by a 1 in the most significant bit.

Output data

none

8.1.7.2 Module 2: Resolution

Description

With this module, the resolution for the position value of module 1 is defined. The BPS 34 also performs a rounding correction (The position value is divided by the defined value range).



Notice!

The resolution only determines the mathematical decimal value and has no effect on the measurement accuracy.

Parameter

Parameter	Description	Rel. addr.	Data type	Value range	Default	Unit	CR to module
a Resolution in [mm]	The parameter specifies the resolution for the position value. The resolution has no effect on - Static preset - Dynamic preset - Offset	0	unsign 8	1: 0.01 2: 0.1 3: 1 4: 10 5: 100 6: 1'000	3	mm	-
Parameter length: 1 byte							

Hex coding of module 2 "Resolution"

The value listed in the table shows the hex coding of the default settings.

Internal address of module 2	Resolution
0A	03

Input data

none

Output data

none

8.1.7.3 Module 3: Static preset



Notice!

Underlined in the CR column are the modules which must be activated in addition to the current module.

Description

With this module, a preset value can be defined which the BPS 34 outputs following a teach event. Defined as a teach event is either bit 0.0 in the output data of this module or a switching input function. After reading in the teach event, the current position value is replaced by the preset value and the position value now calculated and output on the basis of the preset value. The preset remains stored in the BPS 34 and remains active even following a new start. In order for the BPS 34 to again output the position value without the preset, bit 0.1 in the output data must be set.



Notice!

In the event of a device change, the preset value is retained in the MS 34 10x. The activation of the preset value (preset teach) at the intended position is not necessary.

Parameter

Parameter	Description	Rel. addr.	Data type	Value range	Default	Unit	CR to module
<u>a</u> Static preset value in [mm]	New position value after teach event	0	unsign 32	0 ... 10'000'000	0	mm	<u>12c</u> <u>7g</u> or <u>3b</u>
Parameter length: 4 byte							



Notice!

*The preset value is **always entered in units of mm**, independent of the resolution setting (module 2). The scaling factor (module 6) has no effect on the static preset value.*

Hex coding of module 3 "Static preset"

The value listed in the table shows the hex coding of the default settings.

Internal address of module 3	Static preset
06	00 00 00 00

Input data

none

Output data

Output data	Description	Rel. addr.	Data type	Value range	Default	Unit	CR to module
^b Preset teach	Read in the preset value	0.0	Bit	0->1 = Teach	0	–	–
^c Preset reset	Preset value is deactivated.	0.1	Bit	0->1 = Reset	0	–	–
Output data length: 1 byte							

8.1.7.4 Module 4: Dynamic preset



Notice!

Underlined in the CR column are the modules which must be activated in addition to the current module.

Description

With this module, a preset value can be defined which the BPS 34 outputs following a teach event. Defined as a teach event is either bit 0.0 in the output data of this module or a switching input function. After reading in the preset, the current position value is replaced by the preset value and the position now calculated and output on the basis of the preset. The preset remains stored in the BPS 34 and remains active even following a new start. In order for the BPS 34 to again output the tape value, bit 0.1 in the output data must be set (preset reset). The preset value is transmitted to the BPS 34 together with the output data of the PROFIBUS master. Thus, it can be changed during operation (dynamically).

Parameter

none

Input data

none

Output data

Output data	Description	Rel. addr.	Data type	Value range	Default	Unit	CR to module
^a Preset teach	Read in the preset value	0.0	Bit	0->1 = Teach	0	–	12c 12d 7g or 4a
^b Preset reset	Reset to default, deactivate preset value	0.1	Bit	0->1 = Reset	0	–	
^c Preset value	New position value after preset teach	1	unsign 32	0 ... 10'000'000	0	mm	
Output data length: 5 byte							



Notice!

*The preset value is **always entered in units of mm**, independent of the resolution setting (module 2). The scaling factor (module 6) has no effect on the dynamic preset value.*

8.1.7.5 Module 5: Offset value



Notice!

Underlined in the CR column are the modules which must be activated in addition to the current module.

Description

This module adds an offset value to the tape value.

Parameter

Parameter	Description	Rel. addr.	Data type	Value range	Default	Unit	CR to module
<u>Offset value in [mm]</u>	Offset value added to tape value	0	sign32	-10'000'000 ... 10'000'000	0	mm	<u>1</u>
Parameter length: 4 byte							



Notice!

If module 3 "Static preset" or module 4 "Dynamic preset" is activated and, as a result, a new value assigned to the tape value, the offset function no longer affects the position value. The offset is not reactivated until the preset function (static and dynamic) is cancelled. The offset value is entered in mm. When entering the offset value, the scaling in module 6 must be taken into account.

Hex coding of module 5 "Offset value"

The value listed in the table shows the hex coding of the default settings.

Internal address of module 5	Offset value
09	00 00 00 00

Input data

none

Output data

none

8.1.7.6 Module 6: Scaling



Notice!

Underlined in the CR column are the modules which must be activated in addition to the current module.

Description

The scaling function is used to convert the tape values to any unit of measurement. To do this, the tape value is multiplied by the scaling factor.

Parameter

Parameter	Description	Rel. addr.	Data type	Value range	Default	Unit	CR to module
<u>Scaling factor in [%]</u>	Scaling factor used to convert the position values	0	unsign 16	0 ... 65'535	1'000	Per thousand	<u>1</u>
Parameter length: 2 byte							



Notice!

When entering offset values in module 5, it must be ensured that the scaling factor is taken into account.

Affected by this module are:

- *Offset value (module 5)*
- *Static position limit values 1 and 2 (modules 14 and 15)*
- *Hysteresis of static position limit values 1 and 2 (modules 14 and 15)*
- *Dynamic position limit values 1 and 2 (modules 16 and 17)*
- *Hysteresis of dynamic position limit values 1 and 2 (modules 16 and 17)*

The static preset or dynamic preset modules (module 3 or module 4) are not affected by the scaling.

Hex coding of module 6 "Scaling"

The value listed in the table shows the hex coding of the default settings.

Internal address of module 6	Scaling factor
08	03 E8

Input data

none

Output data

none

8.1.7.7 Module 7: Switching input



Notice!

Underlined in the CR column are the modules which must be activated in addition to the current module.

Description

The module defines the mode of operation of the digital switching input.

Parameter

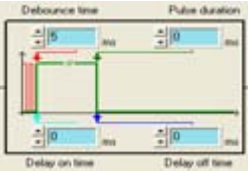
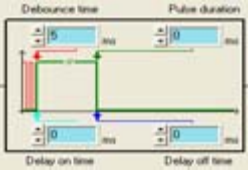
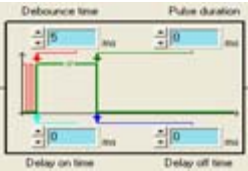
Parameter	Description	Rel. addr.	Data type	Value range	Default	Unit	CR to module
a Inversion	The parameter defines the logic of the pending signal. In case of an inversion, an external HIGH level is interpreted as an internal LOW level.	0	unsign 8	0: No (active high) 1: Yes (active low)	0	–	–
b Mode	This parameter controls the release of the switching input.	1	unsign 8	0: Off 1: On	1	–	–
c Debounce time in [ms]	This parameter defines a debounce time which is implemented in software. 	2	unsign 8	0 ... 255	5	ms	–
d Start-up delay in [ms]	The parameter influences the timing during switch-on. 	3	unsign 16	0 ... 65'535	0	ms	–
e Pulse duration in [ms]	The parameter defines the minimum pulse duration of the input signal. 	5	unsign 16	0 ... 65'535	0	ms	–

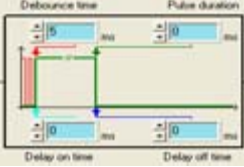
<p>f</p> <p>Switch-off delay in [ms]</p>	<p>The parameter defines a time delay for the signal during switch-off.</p> 	<p>7</p>	<p>unsign 16</p>	<p>0 ... 65'535</p>	<p>0</p>	<p>ms</p>	<p>–</p>
<p>g</p> <p>Function</p>	<p>The parameter specifies the function which is to be activated or deactivated by a change of state at the switching input.</p>	<p>9</p>	<p>unsign 8</p>	<p>0: No function 4: Teach preset 5: Reset min/max position 7: Start position measurement 9: Stop position measurement 10: Teach limit value 1 11: Teach limit value 2 12: Reset min/max velocity 13: Start velocity measurement 14: Stop velocity measurement</p>	<p>7</p>	<p>–</p>	<p>– <u>3a</u> or <u>4c</u> <u>13e</u> <u>9a</u> <u>9b</u> <u>14a 16a</u> <u>15a 17a</u> <u>22b</u> <u>24</u> <u>22a</u> <u>22b</u></p>
<p>Parameter length: 10 bytes</p>							

Hex coding of module 7 "Switching input"

The value listed in the table shows the hex coding of the default settings.

Internal address of module 7	Inversion address 0	Mode address 1	Debounce time address 2	Start-up delay address 3	Pulse duration address 5	Switch-off delay address 7	Function address 9
01	00	01	05	00 00	00 00	00 00	04

Input data

Input data	Description	Rel. addr.	Data type	Value range	Default	Unit	CR to module
h State	State of the signal of the switching input	0.0	Bit	0: Input not active 1: Input active	0	–	–
<p>Input data length: 1 byte</p>							

Output data

none

8.1.7.8 Module 8: Switching output



Notice!

Underlined in the CR column are the modules which must be activated in addition to the current module.

Description

The module defines the mode of operation of the digital switching output.

Parameter

Parameter	Description	Rel. addr.	Data type	Value range	Default	Unit	CR to module
a DC bias level	The parameter defines the DC bias level of the switching output.	0	unsign 8	0: LOW (0V) 1: HIGH (+U _B)	0	–	–
b Velocity limit value selection	Defines whether the switching output is controlled by static velocity limit value 1, static velocity limit value 2, static velocity limit value 3, static velocity limit value 4 or the dynamic velocity limit value	1.0 1.1 1.2 1.3 1.4	Bits	for each 0: No 1: Yes	0 0 0 0 0	–	<u>25</u> for static <u>26</u> for dynamic
c Pulse duration in [ms]	The parameter defines the switch-on time period for the switching output. If the value is 0, the signal is static.	2	unsign 16	0 ... 1'300	400	ms	–
d Switch-on function [ON]	The parameter defines the events which set the switching output: - velocity valid - velocity not valid - position limit value 1 reached - position limit value 1 not reached - outside measurement range - inside measurement range - position limit value 2 reached - position limit value 2 not reached - erroneous measurement - successful measurement - PROFIBUS positive edge - PROFIBUS negative edge - velocity limit value reached - velocity limit value not reached	4.0 4.1 4.2 4.3 4.4 4.5 4.6 4.7 5.2 5.3 5.4 5.5 5.6 5.7	Bits	for each 0: Not active 1: Active	0 0 0 0 0 0 0 0 0 0 0 0 0 0 0 0 1 0 0 0 0 0 0 0	–	22 22 14 + 16 14 + 16 10 10 15 + 17 15 + 17 1 + 9 8 1 + 9 8 8 25 25 <u>25</u>

e Switch-off function [OFF]	The parameter specifies the events which reset the switching output:					
	- velocity valid	6.0			0	22
	- velocity not valid	6.1			0	22
	- position limit value 1 reached	6.2			0	14 + 16
	- position limit value 1 not reached	6.3			0	14 + 16
	- outside measurement range	6.4			0	10
	- inside measurement range	6.5			0	10
	- position limit value 2 reached	6.6			0	15 + 17
	- position limit value 2 not reached	6.7			0	15 + 17
	- erroneous measurement	7.2			0	1 + 9
	- successful measurement	7.3			1	1 + 9
	- PROFIBUS positive edge	7.4			0	8
	- PROFIBUS negative edge	7.5			0	8
- velocity limit value reached	7.6			0	25	
- velocity limit value not reached	7.7			0	25	
Parameter length: 8 byte						



Notice!

The events of the switch-on function and switch-off function are both linked to one another with a logical OR.

Hex coding of module 8 "Switching output"

The value listed in the table shows the hex coding of the default settings.

Internal address of module 8	DC bias level address 0	Velocity limit value selection address 1	Pulse duration address 2	Switch-on function address 4	Switch-off function address 6
02	00	00	01 90	04 00	08 00

Input data

none

Output data

Output data	Description	Rel. addr.	Data type	Value range	Default	Unit	CR to module
f Switching output PROFIBUS edge	This bit can be used to operate the switching output if the "PROFIBUS edge" function is configured.	0.0	Bit	0 -> 1: Positive edge 1 -> 0: Negative edge	0	-	-
Output data length: 1 byte							



Notice!

With the "PROFIBUS edge" function, the switching output can be directly activated or deactivated by setting bit 0.0.

8.1.7.9 Module 9: Controller

Description

The Control module manages timing of the position calculation by starting and stopping the decoding. Control is performed depending on certain events such as the switching input, time functions or PROFIBUS output bits. Using parameters, the events which influence the states are determined.

Parameter

Parameter	Description	Rel. addr.	Data type	Value range	Default	Unit	CR to module
a Measurement start mode	The start mode determines by which event the position measurement is started.	0	unsign 8	0: Deactivated 1: After initialisation 2: By event: Switching input or start event by setting output bit 0.0	1	–	7 g
b Measurement stop mode	The measurement stop mode determines after which event the position measurement is stopped.	1	unsign 8	0: No function 1: After valid measurement result 2: After timeout (stop timeout) 3: After timeout with retrigger (stop timeout) by setting output bit 0.0 or by the switching input 4: By stop event or by setting output bit 0.1 or by the switching input (the switching input must be programmed for this purpose) 5: By an error	4	–	7 g
c Stop timeout in [ms]	Time for stop timeout	2	unsign 16	0 ... 65'535	10'000	ms	–
Parameter length: 4 byte							

Hex coding of module 9 "Control"

The value listed in the table shows the hex coding of the default settings.

Internal address of module 9	Measurement start mode address 0	Measurement stop mode address 1	Stop timeout address 2
03	01	04	27 10

Input data

Input data	Description	Rel. addr.	Data type	Value range	Default	Unit	CR to module
^d Status of position controller	Signals the current state of the internal position control of the BPS 34	0	unsigned 8	0: Init 1: Idle 2: Measure 4: Standby	0	-	-
Input data length: 1 byte							



Notice!

These input data signal the state of the BPS 34:

- **Init:** Base setting during initial startup of the BPS 34
- **Idle:** The BPS 34 is in idle state (scanning beam is off, but motor is running)
- **Measure:** The BPS 34 is in measurement state (data are output in module 1)
- **Standby:** The BPS 34 is in waiting state (laser off and motor off).

Output data

Output data	Description	Rel. addr.	Data type	Value range	Default	Unit	CR to module
^e Start event	Event starts position measurement	0.0	Bit	0 -> 1: Start	0	-	7 g
^f Stop event	Event stops position measurement	0.1	Bit	0 -> 1: Stop	0	-	-
^g BPS standby	Switches the BPS 34 to standby operation	0.7	Bit	0: BPS active 1: BPS in standby	0	-	-
Output data length: 1 byte							



Notice!

The standby function can only be activated while in "Measure" state. This function switches off the motor and laser. It takes approx. 2 sec. to switch the BPS 34 back on (valid measurement values at the interface)

In "Idle" state, the motor continues to run. Only the laser is switched off. It takes approx. 1 sec. to switch the BPS 34 back on (valid measurement values at the interface)

If the start-stop event is to occur at the switching input, the "function" parameter must be configured with the "start/stop measurement" parameter in module 7 "Switching input".

8.1.7.10 Module 10: Measurement value acquisition

Description

With this module, a working range on the barcode tape can be defined. The BPS 34 outputs position values within these minimum and maximum limits. Outside of these limits, a position value of zero is output.

Parameter

Parameter	Description	Rel. addr.	Data type	Value range	Default	Unit	CR to module
Max. measurement length in [mm] ^a	Maximum permitted measurement length	0	unsign 32	0 ... 2'147'483'647	10'000'000	mm	8d
Min. measurement length in [mm] ^b	Minimum permitted measurement length	4	unsign 32	0 ... 2'147'483'647	0	mm	8d
Parameter length: 8 byte							



Notice!

The signal output can be used to indicate that the measured value is outside of the measurement range. To enable this function, the "outside measurement range" or "inside measurement range" parameter must be activated in module 8.

Hex coding of module 10 "Measurement value acquisition"

The value listed in the table shows the hex coding of the default settings.

Internal address of module 10	Max. measurement length address 0	Min. measurement length address 4
04	00 98 96 80	00 00 00 00

Input data

none

Output data

none

8.1.7.11 Module 11: Measurement value processing

Description

The integration depth parameter is used to specify the number of raw position data which is used for integration in order to determine the position value.

In order to obtain positive or negative position values depending on the direction of movement of the BPS 34, the count direction can be selected as normal or inverted in the output data of this module.

In order to obtain more exact measurement data while in the static state or for very slow travel speeds, the integration depth can be increased here. If, however, a high integration depth is used for high speeds, the contouring error is increased. With respect to contouring error and exact measurement data, very good results have been obtained using 8 integration steps. Using 8 integration steps, the integration time is 16ms. Thus, the BPS 34 delivers a new position value to the interface every 2ms which is 8ms old.

Parameter

Parameter	Description	Rel. addr.	Data type	Value range	Default	Unit	CR to module
a Integration depth	Number of consecutive scans which are to be used for position determination.	0	unsign 8	4 ... 15	8	Measurements	8d
Parameter length: 2 byte							

Integration depth	Integration time [ms]
4	8
5	10
6	12
7	14
8 (default)	16
9	18
10	20
11	22
12	24
13	26
14	28
15	30

Hex coding of module 11 "Measurement value preparation"

The value listed in the table shows the hex coding of the default settings.

Internal address of module 11	Integration depth address 0
05	00 08

Input data

none

Output data

Output data	Description	Rel. addr.	Data type	Value range	Default	Unit	CR to module
b Count direction	Count direction for position calculation	0.0	Bit	0: Normal : Inverted	0	-	-
Output data length: 1 byte							



Notice!

The BPS 34 is set as follows by default:

The position value is output with "normal" count direction. With the "inverted" count direction, 10'000'000mm minus the position value is output. This behaviour can be influenced using the "Static preset"/"Dynamic preset" modules (module 3 and module 4, respectively) and the "Offset" module (module 5).

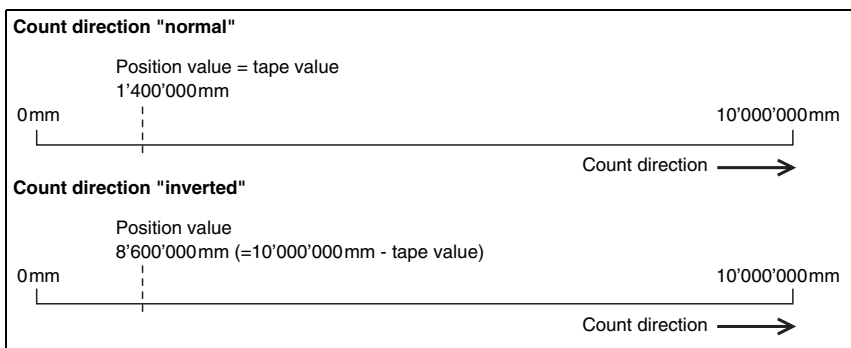

Figure 8.12: Count direction for position calculation

8.1.7.13 Module 12: Status



Notice!

Underlined in the CR column are the modules which must be activated in addition to the current module.

Description

This module supplies various BPS 34 status information to the PROFIBUS master.

Parameter

none

Input data

Input data	Description	Rel. addr.	Data type	Value range	Default	Unit	CR to module
a Measurement error	Indicates that no valid integration value could be determined (measurement value preparation module).	0.0	Bit	0: OK 1: Error	0	–	–
b Range status	Indicates that measurement range has been exceeded (measurement value acquisition module)	0.1	Bit	0: OK, within measurement range 1: Measurement range exceeded	0	–	<u>10</u>
c Preset active	Indicates a position-value output with active static preset or dynamic preset (Preset module)	0.2	Bit	0: No preset active 1: Preset active	0	–	<u>3a</u> <u>4c</u>
d Preset teach	Toggle bit, changes during the teach event for the static and dynamic preset value (Preset module)	0.3	Bit	0,1: Dyn. preset teach	0	–	<u>3a</u> <u>4c</u>
e Position limit value status 1 (static or dynamic)	Indicates that limit value 1 has been exceeded (measurement value monitoring module).	0.4	Bit	0: No limit value violation 1: Value greater than limit	0	–	14d 16d
f Position limit value status 2 (static or dynamic)	Indicates that limit value 2 has been exceeded (measurement value monitoring module).	0.5	Bit	0: No limit value violation 1: Value greater than limit	0	–	15d 17d
g Standby status	Signals the standby status (Control module)	0.7	Bit	0: BPS active 1: BPS in standby	0	–	9d
Input data length: 1 byte							

Output data

none

8.1.7.14 Module 13: Min/Max position



Notice!

Underlined in the CR column are the modules which must be activated in addition to the current module.

Description

The Min/Max position function monitors the position value and transfers the maximum/minimum value to the PROFIBUS master.

The acquisition time can be adjusted by means of two different modes:

- The "all values" mode detects all values since the start of measurement or since a reset event.
- The "in measurement value window only" mode only detects extreme values which occur in the time period defined in the "MinMax period" parameter.

Parameter

Parameter	Description	Rel. addr.	Data type	Value range	Default	Unit	CR to module
<u>a</u> MinMax mode	Parameter activates Min/Max evaluation function.	0	unsign 8	0: Off 1: All values 2: In measurement value window only	0	–	–
<u>b</u> MinMax period	Defines the measurement value window for the min-max values.	1	unsign 8	0 ... 255	10	Measurements	–
Parameter length: 2 byte							

Hex coding of module 13 "Min/Max position"

The value listed in the table shows the hex coding of the default settings.

Internal address of module 13	MinMax mode address 0	MinMax period address 1
0C	00	0A

Input data

Input data	Description	Rel. addr.	Data type	Value range	Default	Unit	CR to module
c Min position	Minimum position for detected period.	0	sign32	-10'000'000 ... 10'000'000	0 Reset: 2'147'483'647	scaled	-
d Max position	Maximum position for detected period.	4	sign32	-10'000'000 ... 10'000'000	0 Reset: -2'147'483'647	scaled	-
Input data length: 8 byte							

Output data

Output data	Description	Rel. addr.	Data type	Value range	Default	Unit	CR to module
e MinMax reset	Signal for resetting extreme values	0.0	Bit	0 -> 1: Reset	0	-	7
Output data length: 8 byte							



Notice!

With "MinMax reset", the input data are reset to 155812h.

With this module, the settings for the Preset (module 3), Offset (module 5) and Scaling (module 6) modules must be taken into account.

8.1.7.15 Module 14: Static position limit value 1

Description

The limit value function compares the output position value with a position stored during configuring. If the value is above or below the limit value, the limit value status 1 (module 12) is set and, if configured, the switching output (module 8) is appropriately set.

Parameter

Parameter	Description	Rel. addr.	Data type	Value range	Default	Unit	CR to module
a Limit value mode 1	Parameter activates limit value checking.	0	unsign 8	0: Off 1: On	0	–	7 g
b Switching mode 1	Condition for the signal change of the switching output/status bit.	1	unsign 8	0: Value greater than limit 1: Value less than limit	0	–	8d
c Hysteresis 1 in [mm]	Relative offset of switching point	2	unsign 16	0 ... 65'535	0	mm	–
d Limit value 1 in [mm]	Limit value is compared to the current position value.	4	sign32	-10'000'000 ... 10'000'000	0	mm	12e
Parameter length: 8 byte							

Hex coding of module 14 "Static position limit value 1"

The value listed in the table shows the hex coding of the default settings.

Internal address of module 14	Limit value mode 1 address 0	Switching mode 1 address 1	Hysteresis 1 address 2	Limit value 1 address 4
0D	00	00	00 00	00 00 00 00

Input data

none

Output data

none



Notice!

With this module, the settings for the Preset (module 3), Offset (module 5) and Scaling (module 6) modules must be taken into account.

8.1.7.16 Module 15: Static position limit value 2

Description

The limit value function compares the output position value with a position stored during parameterisation. If the value is above or below the limit value, the limit value status 2 (module 12) is set and, if configured, the switching output (module 8) is appropriately set.

Parameter

Parameter	Description	Rel. addr.	Data type	Value range	Default	Unit	CR to module
a Limit value mode 2	Parameter activates limit value checking.	0	unsign 8	0: Off 1: On	0	–	7 g
b Switching mode 2	Condition for the signal change of the switching output/status bit.	1	unsign 8	0: Value greater than limit 1: Value less than limit	0	–	8d
c Hysteresis 2 in [mm]	Relative offset of switching point	2	unsign 16	0 ... 65'535	0	mm	–
d Limit value 2 in [mm]	Limit value is compared to the current position value.	4	sign32	-10'000'000 ... 10'000'000	0	mm	12f
Parameter length: 8 byte							

Hex coding of module 15 "Static position limit value 2"

The value listed in the table shows the hex coding of the default settings.

Internal address of module 15	Limit value mode 2 address 0	Switching mode 2 address 1	Hysteresis 2 address 2	Limit value 2 address 4
0E	00	00	00 00	00 00 00 00

Input data

none

Output data

none



Notice!

With this module, the settings for the Preset (module 3), Offset (module 5) and Scaling (module 6) modules must be taken into account.

8.1.7.17 Module 16: Dynamic position limit value 1

Description

The limit value function compares the position value with a stored position. If the value is above or below the limit value, the limit value status 1 in module 12 is set and, if configured, the switching output is appropriately set.

The limit value is transferred to the BPS 34 together with the output data of this module by the PROFIBUS master.

Parameter

Parameter	Description	Rel. addr.	Data type	Value range	Default	Unit	CR to module
a Limit value mode 1	Parameter activates limit value checking.	0	unsign 8	0: Off 1: On	0	–	7 g
b Switching mode 1	Condition for the signal change of the switching output/status bit.	1	unsign 8	0: Value greater than limit 1: Value less than limit	0	–	8d 12e
c Hysteresis 1 in [mm]	Relative offset of switching point.	2	unsign 16	0 ... 65'535	0	mm	–
Parameter length: 4 byte							

Hex coding of module 16 "Dynamic position limit value 1"

The value listed in the table shows the hex coding of the default settings.

Internal address of module 16	Limit value mode 1 address 0	Switching mode 1 address 1	Hysteresis 1 address 2
0F	00	00	00 00

Input data

none

Output data

Output data	Description	Rel. addr.	Data type	Value range	Default	Unit	CR to module
d Limit value 1 in [mm]	Limit value is compared to the current position value.	0	sign32	-10'000'000 ... 10'000'000	0	mm	–
Output data length: 4 byte							



Notice!

With this module, the settings for the Preset (module 3), Offset (module 5) and Scaling (module 6) modules must be taken into account.

8.1.7.18 Module 17: Dynamic position limit value 2

Description

The limit value function compares the position value with a stored position. If the value is above or below the limit value, the limit value status 2 in module 12 is set and, if configured, the switching output is appropriately set.

The limit value is transferred to the BPS 34 together with the output data of this module by the PROFIBUS master.

Parameter

Parameter	Description	Rel. addr.	Data type	Value range	Default	Unit	CR to module
^a Limit value mode 2	Parameter activates limit value checking.	0	unsign 8	0: Off 1: On	0	–	7 g
^b Switching mode 2	Condition for the signal change of the switching output/status bit.	1	unsign 8	0: Value greater than limit 1: Value less than limit	0	–	8d 12f
^c Hysteresis 2 in [mm]	Relative offset of switching point.	2	unsign 16	0 ... 65'535	0	mm	–
Parameter length: 4 byte							

Hex coding of module 17 "Dynamic position limit value 2"

The value listed in the table shows the hex coding of the default settings.

Internal address of module 17	Limit value mode 2 address 0	Switching mode 2 address 1	Hysteresis 2 address 2
10	00	00	00 00

Input data

none

Output data

Output data	Description	Rel. addr.	Data type	Value range	Default	Unit	CR to module
^d Limit value 2 in [mm]	Limit value is compared to the current position value.	0	sign32	-10'000'000 ... 10'000'000	0	mm	–
Output data length: 4 byte							



Notice!

With this module, the settings for the Preset (module 3), Offset (module 5) and Scaling (module 6) modules must be taken into account.

8.1.7.19 Module 18: Measuring error tolerance

Description

The measuring error tolerance function is used to configure a time which results in an extended output of the last position value (module 1) in the event of an error. If the position value changes momentarily to zero, e.g. due to a brief interruption of the laser beam, soiling of the barcode tape or other short-term disturbances, the BPS transmits the last valid position value.

If the error disappears within the configured time, the control notices nothing or only a small change in the position value. The availability of the system is thereby ensured. No new values are delivered by the BPS 34, however, for a period of time extending up to the configured tolerance time. With the "delay error output" parameter, an integration error (corresponds to a missing position value) can be signalled immediately or after the tolerance time has elapsed. If the error persists after the tolerance time has elapsed, a position value of zero is output.

Parameter

Parameter	Description	Rel. addr.	Data type	Value range	Default	Unit	CR to module
a Position tolerance time in [ms]	Specifies the time for the output of the last position value following an error	0	unsign 16	0 ... 65'535	50	ms	-
b Delay error output	Delays the output of an integration error by the configured tolerance time.	2	unsign 8	0: No, error delay deactivated 1: Yes, error delay activated	1	-	-
Parameter length: 3 bytes							

Hex coding of module 18 "Measuring error tolerance"

The value listed in the table shows the hex coding of the default settings.

Internal address of module 18	Position tolerance time address 0	Delay error output address 2
14	00 32	01

Input data

none

Output data

none

8.1.7.20 Module 19: Service

Description

The "service" function is used to reset the parameter set of the BPS 34 to default settings. This reset only occurs directly in the BPS 34. After the reset function has been activated, the device carries out a reset and is freshly configured on the PROFIBUS. This results in the reactivation of all modules and parameter settings selected in the PROFIBUS project.

Parameter

none

Input data

Input data	Description	Rel. addr.	Data type	Value range	Default	Unit	CR to module
a Status byte	Shows the state of the reset to factory settings	0	unsign 8	0x00: Not active or successfully concluded 0xFF: Reset active 0xF1: EEPROM access error	0x00	-	-
Input data length: 1 byte							

Output data

Output data	Description	Rel. addr.	Data type	Value range	Default	Unit	CR to module
b Factory settings	Reset of parameters to factory settings.	0.0	Bit	0 -> 1: Reset the parameters 1 -> 0: Standard operation	0	-	-
Output data length: 1 byte							



Notice!

The preset function (module 3) must be retight following a reset.

8.1.1.7.21 Module 20: Velocity



Notice!

Underlined in the CR column are the modules which must be activated in addition to the current module.

Description

Outputs the current velocity with the configured resolution and the desired scaling factor. In order for the velocity to be calculated in the BPS 34 and output in this module, module 22 (Control velocity) must also be activated in the PROFIBUS project.

Parameter

none

Input data

Input data	Description	Rel. addr.	Data type	Value range	Default	Unit	CR to module
<u>a</u> Velocity	Current velocity	0	unsign 32	0 ... 10'000'000	0	scaled	<u>22</u>
Input data length: 4 byte							



Notice!

The scaling of the position value has no effect on the scaling or output of the velocity.

The direction of movement of the BPS 34 is displayed in module 23 "Velocity measurement status" (see page 82) under h "Direction of movement".

Output data

none

8.1.7.22 Module 21: Velocity parameters

Description

The velocity parameter influences the fundamental method of operation and output of the velocity measurement. The resolution, scaling, integration depth and error tolerance for the velocity measurement can be defined.

The resolution function defines the resolution for the velocity value (module 20). The scaling function allows the velocity values to be converted to any unit of measurement. To do this, the velocity value (module 20) is multiplied by the scaling factor. The velocity integration depth parameter averages the selected number of velocity values to produce the velocity output in module 20.

The velocity tolerance time function is used to configure a time which results in an extended output of the last velocity (module 20) in the event of an error. If the speed could not be calculated momentarily, e.g. due to a brief interruption of the scanning beam, soiling of the barcode tape or other short-term disturbances, the BPS transmits the last valid velocity. If the error disappears within the configured time, the control notices nothing or only a small change in the velocity value. The availability of the system is thereby ensured.

The "delay velocity error output" parameter can be used to signal a velocity error with bit 0.0 either immediately or after the velocity tolerance time in module 23 has elapsed. If the error persists after the tolerance time has elapsed, a velocity value of zero is output.

Parameter

Parameter	Description	Rel. addr.	Data type	Value range	Default	Unit	CR to module
^a Velocity resolution in [mm/s]	The parameter specifies the resolution for the velocity value.	0	unsign 8	3: 1 4: 10 5: 100 6: 1'000	3	mm/s	20a
^b Velocity scaling factor in [%]	Scaling factor used to convert the velocity	1	unsign 16	0 ... 65'535	1'000	Per thousand	
^c Velocity integration depth	Number of consecutive measurements which are to be used for velocity determination. Specified here is the integration time (see table on page 79).	3	unsign 8	2 ... 128	8	ms	
^d Velocity tolerance time in [ms]	Specifies the time for the display of the last velocity following an error	4	unsign 16	0 ... 65'535	50	ms	
^e Delay velocity error output	Delays the output of a velocity error by the configured tolerance time.	6	unsign 8	0: No, error delay deactivated 1: Yes, error delay activated	1	–	23a
Parameter length: 7 bytes							

Velocity integration depth	Integration time [ms]
1	2
2	4
3	6
4 (default)	8
5	10
:	:
63	126
64	128

Hex coding of module 21 "Velocity parameters"

The value listed in the table shows the hex coding of the default settings.

Internal address of module 21	Velocity resolution address 0	Velocity scaling factor address 1	Velocity integration depth address 3	Velocity tolerance time address 4	Delay velocity error output address 6
17	03	03 E8	08	00 32	01

Input data

none

Output data

none

8.1.7.23 Module 22: Velocity measurement control

Description

The control manages the timing of the velocity measurement by starting or stopping the measurement function. Control is performed depending on certain events such as the switching input, time functions or PROFIBUS output bits. Using parameters, it determines the events which influence the states.

Parameter

Parameter	Description	Rel. addr.	Data type	Value range	Default	Unit	CR to module
a Velocity measurement start mode	The start mode determines by which event the velocity measurement is started.	0	unsigned	0: Deactivated 1: After initialisation 2: Following event: either by the switching input or by a signal from the PROFIBUS master	0	–	7 g
b Velocity measurement stop mode	The stop mode determines after which event the velocity measurement is stopped.	1	unsigned	0: Deactivated 1: By an error 2: By a stop event: either by output bit 0.1 or by the switching input function	0	–	7 g
Parameter length: 2 byte							

Hex coding of module 22 "Velocity measurement"

The value listed in the table shows the hex coding of the default settings.

Internal address of module 22	Velocity measurement start mode address 0	Velocity measurement stop mode address 1
18	00	00

Input data

Input data	Description	Rel. addr.	Data type	Value range	Default	Unit	CR to module
^c State	Signals the current state of the internal velocity measurement of the BPS 34	0	unsigned 8	0: Init 1: Idle 2: Measure 4: Standby	0	–	–
Input data length: 1 byte							



Notice!

These input data signal the state of the BPS 34:

- **Init:** Base setting during initial startup of the BPS 34
- **Idle:** The BPS 34 is in idle state (scanning beam is off, but motor is running)
- **Measure:** The BPS 34 is in measurement state (data are output in module 1)
- **Standby:** The BPS 34 is in waiting state (laser off and motor off).

Output data

Output data	Description	Rel. addr.	Data type	Value range	Default	Unit	CR to module
^d Start event	Event starts velocity measurement.	0.0	Bit	0 -> 1: Start	0	–	–
^e Stop event	Event stops velocity measurement.	0.1	Bit	0 -> 1: Stop	0	–	–
^f Min/Max velocity mode	Defines whether the current velocity is included in min/max recording.	0.2	Bit	0: Do not record min/max 1: Record min/max	0	–	24
^g Min/Max velocity reset	Reset the min/max velocity values.	0.3	Bit	0 -> 1: Reset	0	–	24
Output data length: 1 byte							

8.1.7.24 Module 23: Velocity measurement status

Description

This module supplies various status information regarding the velocity measurement of the BPS 34 to the PROFIBUS master.

Parameter

none

Input data

Input data	Description	Rel. addr.	Data type	Value range	Default	Unit	CR to module
a Velocity measurement error	Signals that no valid velocity could be ascertained.	0.0	Bit	0: OK 1: Error	0	–	21
b Velocity limit value status 1	Signals that velocity limit value 1 has been exceeded.	0.1	Bit	0: No limit value violation 1: Value greater than limit	0	–	25a
c Velocity limit value status 2	Signals that velocity limit value 2 has been exceeded.	0.2	Bit	0: No limit value violation 1: Value greater than limit	0	–	25a
d Velocity limit value status 3	Signals that velocity limit value 3 has been exceeded.	0.3	Bit	0: No limit value violation 1: Value greater than limit	0	–	25a
e Velocity limit value status 4	Signals that velocity limit value 4 has been exceeded.	0.4	Bit	0: No limit value violation 1: Value greater than limit	0	–	25a
f Dyn. velocity limit value status	Signals that the dynamic velocity limit value has been exceeded.	0.5	Bit	0: No limit value violation 1: Value greater than limit	0	–	26b
g Movement status	Signals whether a movement is currently being detected.	0.6	Bit	0: No movement 1: Movement	0	–	–
h Direction of movement	If bit 6 is set, the direction of movement can be read here.	0.7	Bit	0: Direction - tape start 1: Direction - tape end	0	–	–
i Velocity limit value status 1	Signals whether the current velocity is compared with this limit value.	1.1	Bit	0: Comparison not active 1: Comparison active	0	–	25a
j Velocity limit value status 2	Signals whether the current velocity is compared with this limit value.	1.2	Bit	0: Comparison not active 1: Comparison active	0	–	25a
k Velocity limit value status 3	Signals whether the current velocity is compared with this limit value.	1.3	Bit	0: Comparison not active 1: Comparison active	0	–	25a
l Velocity limit value status 4	Signals whether the current velocity is compared with this limit value.	1.4	Bit	0: Comparison not active 1: Comparison active	0	–	25a
m Dyn. velocity limit value status	Signals whether the current velocity is compared with this limit value.	1.5	Bit	0: Comparison not active 1: Comparison active	0	–	26a
Input data length: 2 byte							



Notice!

The movement status **g** is displayed for velocities from 0.01 m/s.



Attention!

The "Dynamic preset" module (module 4), the "MVS label" function and the "error tolerance time" can be used to activate the a ... **f** messages of the input data. Depending on the configuration, these may be normal states.

Output data

none

8.1.7.25 Module 24: Min/Max velocity

Description

The Min/Max velocity function monitors the velocity value and transfers the maximum and minimum value to the PROFIBUS master. Recording can be controlled via module 22 "Velocity measurement control". It is also possible to reset values to the initialisation value via module 22.

Parameter

none

Input data

Input data	Description	Rel. addr.	Data type	Value range	Default	Unit	CR to module
a Minimum velocity	Minimum velocity for detected period.	0	unsign 32	0 ... 10'000'000	0	scaled	22
b Maximum velocity	Maximum velocity for detected period.	4	unsign 32	0 ... 10'000'000	0	scaled	
Input data length: 8 byte							

Output data

none

8.1.7.26 Module 25: Static velocity limit values



Notice!

Underlined in the CR column are the modules which must be activated in addition to the current module.

Description

The limit value function compares the current velocity with a limit velocity stored in the configuration. This occurs in the range defined by the range start and end. If a direction-dependent limit value check is activated with the "direction selection" parameter, the values of range start and end define the direction. The check is always performed from range start to range end. For example, if the range start is 5500 and the range end is 5000, the direction-dependent check is only performed in the direction from 5500 to 5000. The limit value is not active in the opposite direction. If the check is independent of direction, the order of range start and end is without meaning. If the value is above or below the limit value, the limit value status in module 23 is set and, if configured, the switching output is appropriately set.

Parameter

Parameter	Description	Rel. addr.	Data type	Value range	Default	Unit	CR to module
a Velocity limit value mode	Parameter activates or deactivates limit value checking for Velocity limit value 1, Velocity limit value 2, Velocity limit value 3, Velocity limit value 4, on or off.	0.0 0.1 0.2 0.3	Bits	for each limit value 0: Limit value not active 1: Limit value activated	0 0 0 0	–	8b 22
b Direction selection	Selection of direction-dependent or direction-independent limit value checking for Velocity limit value 1, Velocity limit value 2, Velocity limit value 3, Velocity limit value 4,	0.4 0.5 0.6 0.7	Bits	for each limit value 0: Check in both directions 1: Only check in one direction	0 0 0 0	–	
c Switching mode	Condition for the signal change of the switching output and the status bits for Velocity limit value 1, Velocity limit value 2, Velocity limit value 3, Velocity limit value 4,	1.0 1.1 1.2 1.3	Bits	for each limit value 0: Value greater than limit 1: Value less than limit	0 0 0 0	–	
d Velocity limit value 1 in [mm/s]	Limit value is compared to the current velocity.	2	unsign 16	0 ... 20'000	0	mm/s	23b
e Velocity hysteresis 1 in [mm/s]	Relative offset of switching point.	4	unsign 16	0 ... 20'000	0	mm/s	

f Range start limit value 1 in [mm]	The velocity limit value is monitored beginning at this position.	6	sign32	-10'000'000 ... 10'000'000	0	mm	23b
g Range end limit value 1 in [mm]	The velocity limit value is monitored up to this position.	10	sign32	-10'000'000 ... 10'000'000	0	mm	
h Velocity limit value 2 in [mm/s]	Limit value is compared to the current velocity.	14	unsign 16	0 ... 20'000	0	mm/s	23c
i Velocity hysteresis 2 in [mm/s]	Relative offset of switching point.	16	unsign 16	0 ... 20'000	0	mm/s	
j Range start limit value 2 in [mm]	The velocity limit value is monitored beginning at this position.	18	sign32	-10'000'000 ... 10'000'000	0	mm	
k Range end limit value 2 in [mm]	The velocity limit value is monitored up to this position.	22	sign32	-10'000'000 ... 10'000'000	0	mm	23d
l Velocity limit value 3 in [mm/s]	Limit value is compared to the current velocity.	26	unsign 16	0 ... 20'000	0	mm/s	
m Velocity hysteresis 3 in [mm/s]	Relative offset of switching point.	28	unsign 16	0 ... 20'000	0	mm/s	
n Range start limit value 3 in [mm]	The velocity limit value is monitored beginning at this position.	30	sign32	-10'000'000 ... 10'000'000	0	mm	
o Range end limit value 3 in [mm]	The velocity limit value is monitored up to this position.	34	sign32	-10'000'000 ... 10'000'000	0	mm	23e
p Velocity limit value 4 in [mm/s]	Limit value is compared to the current velocity.	38	unsign 16	0 ... 20'000	0	mm/s	
q Velocity hysteresis 4 in [mm/s]	Relative offset of switching point.	40	unsign 16	0 ... 20'000	0	mm/s	
r Range start limit value 4 in [mm]	The velocity limit value is monitored beginning at this position.	42	sign32	-10'000'000 ... 10'000'000	0	mm	23e
s Range end limit value 4 in [mm]	The velocity limit value is monitored up to this position.	46	sign32	-10'000'000 ... 10'000'000	0	mm	
Parameter length: 50 bytes							

Hex coding of module 25 "Static velocity limit values"

The value listed in the table shows the hex coding of the default settings.

Internal address of module 25	Velocity limit value mode address 0	Direction selection address 0	Switching mode address 1	Velocity limit value 1 address 2	Velocity hysteresis 1 address 4	Range start limit value 1 address 6	Range end limit value 1 address 10
1B	00	00	00	00 00	00 00	00 00 00 00	00 00 00 00

Velocity limit value 2 address 14	Velocity hysteresis 2 address 16	Range start limit value 2 address 18	Range end limit value 2 address 22	Velocity limit value 3 address 26	Velocity hysteresis 3 address 28	Range start limit value 3 address 30	Range end limit value 3 address 34
00 00	00 00	00 00 00 00	00 00 00 00	00 00	00 00	00 00 00 00	00 00 00 00

Velocity limit value 4 address 38	Velocity hysteresis 4 address 40	Range start limit value 4 address 42	Range end limit value 4 address 46
00 00	00 00	00 00 00 00	00 00 00 00

Input data

none

Output data

none

8.1.7.27 Module 26: Dynamic velocity limit value

**Notice!**

Underlined in the CR column are the modules which must be activated in addition to the current module.

Description

The velocity limit value function compares the current velocity with a stored velocity within the defined range. If the value is above or below the limit value, the dynamic limit value status in module 23 is set and, if configured, the switching output is appropriately set. Limit value, hysteresis, range start and range end are transferred with the output data of this module by the PROFIBUS master. The transferred values are activated by bit 0.0, i.e. if this bit is set, the BPS 34 compares the current velocity with the new limit value conditions.

Parameter

none

Input data

none

Output data

Output data	Description	Rel. addr.	Data type	Value range	Default	Unit	CR to module
a Limit value control	Controls internal processing of the transferred dynamic limit value parameters.	0.0	Bit	0: Do not process 1: Parameter now valid / process	0	–	8d 22 23f 23m
b Switching mode	Condition for the signal change of the switching output and the status bit for dynamic velocity limit value.	0.1	Bit	0: Value greater than limit 1: Value less than limit	0	–	
c Direction selection	Selection of direction-dependent or direction-independent limit value checking for dynamic velocity limit value	0.2	Bits	0: Check in both directions 1: Only check in one direction	0	–	
d Dyn. velocity limit value in [mm/s]	Limit value is compared to the current velocity.	1	unsign 16	0 ... 20'000	0	mm/s	
e Dyn. velocity hysteresis in [mm/s]	Relative offset of switching point.	3	unsign 16	0 ... 20'000	0	mm/s	
f Range start dyn. limit value in [mm]	The dynamic velocity limit value is monitored beginning at this position.	5	sign32	-10'000'000 ... 10'000'000	0	mm	8d 22 23f 23m
g Range end dyn. limit value in [mm]	The dynamic velocity limit value is monitored up to this position.	9	sign32	-10'000'000 ... 10'000'000	0	mm	
Output data length: 13 byte							

8.1.7.28 Module 27: Tape value correction

Description

The tape value correction function can be used to correct the length deviation of the barcode tape length from the actual tape length (calibration) which results from the production process. For this purpose, a suitable measuring device must be used to determine the actual length of one metre of barcode tape (as printed). If, for example, one metre of tape has an absolute value of 1001.4 millimetres, the value 10014 is entered in the "real length" parameter of this module. The real length is specified with a resolution of 0.1 millimetres. To use the exact resolution, it is useful to measure a longer section of barcode tape and convert the deviation to a length of one metre.

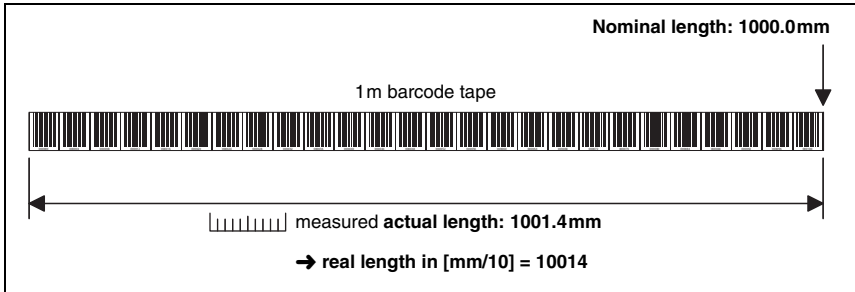

Figure 8.29: Tape value correction

The "range start" parameter must be configured according to the real starting value of the used barcode tape. If several different barcode tapes are connected to one another in sequence, the "range end" of the corrected tape section must also be entered. The entire barcode tape is corrected with the default value of 10'000'000 for the range end.

Parameter

Parameter	Description	Rel. addr.	Data type	Value range	Default	Unit	CR to module
a Real length in [mm/10]	Specifies the real (calibrated) length of one metre of barcode tape (as printed).	0	unsign 16	0 ... 65'535	10'000	mm/10	1
b Range start in [mm]	The tape value is corrected with the real length starting from this position.	2	sign32	0 ... 10'000'000	0	mm	-
c Range end in [mm]	The tape value is corrected with the real length up to this position.	6	sign32	0 ... 10'000'000	10'000'000	mm	-
Parameter length: 10 bytes							

Hex coding of module 27 "Tape value correction"

The value listed in the table shows the hex coding of the default settings.

Internal address of module 27	Real length address 0	Range start address 2	Range end address 6
1D	27 10	00 00 00 00	00 98 96 80

Input data

none

Output data

none

9 Diagnostics and troubleshooting

9.1 General causes of errors

Error	Possible error cause	Measures
LED MS 34 10x = "off"	<ul style="list-style-type: none"> No supply voltage connected to the device. Device not yet recognised by the PROFIBUS <p>Notice: The LED remains off until the BPS 34 is recognised by the PROFIBUS. Only after the PROFIBUS has addressed the BPS 34 for the first time do the following status descriptions apply.</p>	<ul style="list-style-type: none"> <input type="checkbox"/> Check supply voltage. <input type="checkbox"/> Check PROFIBUS settings.
LED MS 34 10x = "flashes red"	<ul style="list-style-type: none"> Error on the PROFIBUS. 	<ul style="list-style-type: none"> <input type="checkbox"/> Reset device (switch voltage on/off).
LED MS 34 10x = "red continuous light" (no communication via PROFIBUS)	<ul style="list-style-type: none"> Incorrect wiring. Wrong termination. Incorrect PROFIBUS address set. PROFIBUS deactivated. Incorrect configuration. Parameter-memory overflow in the control. 	<ul style="list-style-type: none"> <input type="checkbox"/> Check wiring. <input type="checkbox"/> Check termination. <input type="checkbox"/> Check PROFIBUS address. <input type="checkbox"/> Activate PROFIBUS interface. <input type="checkbox"/> Check configuration of the device in the configuration tool. <input type="checkbox"/> Reduce number of modules.
LED MS 34 10x = "orange continuous light"	<ul style="list-style-type: none"> Service operation active. 	<ul style="list-style-type: none"> <input type="checkbox"/> Set the service switch in MSD 1 101 to "Operation"
Position error	<ul style="list-style-type: none"> No barcode tape present. Scanner positioned in total reflection Scanner not properly mounted 	<ul style="list-style-type: none"> <input type="checkbox"/> Check positioning of barcode tape. <input type="checkbox"/> Change the angle of the scanning beam by tilting the BPS 34. <input type="checkbox"/> Check mounting.

9.2 PROFIBUS errors

Error	Possible error cause	Measures
Sporadic errors at the PROFIBUS	<ul style="list-style-type: none"> Incorrect wiring. Wrong termination. Electromagnetic influences. Overall network expansion exceeded. 	<ul style="list-style-type: none"> <input type="checkbox"/> Check wiring. <input type="checkbox"/> Check termination. <input type="checkbox"/> Check shielding. <input type="checkbox"/> Check grounding concept and connection to FE. <input type="checkbox"/> Check max. network expansion as a function of the set baud rate.



Notice!

Please use **page 92 and page 93 as a master copy** should servicing be required.

Cross the items in the "Measures" column which you have already examined, fill out the following address field and fax both pages together with your service contract to the fax number listed below.

Customer data (please complete) Leuze service fax number: +49 7021 573-199

Device type:	
Company:	
Contact partner / department:	
Phone (direct):	
Fax:	
Street / No:	
ZIP code/City:	
Country:	

10 Type overview and accessories

10.1 Type overview: BPS 34

Part No.	Type designation	Remark
50038007	BPS 34 S M 100	PROFIBUS DP interface
50038008	BPS 34 S M 100 H	PROFIBUS DP interface and heating
50103179	BPS 34 S M 100 HT	PROFIBUS DP interface, max. temp up to 50°C

10.2 Accessory modular hoods with integrated connectors

Part No.	Type designation	Remark
50037230	MS 34 103	Modular hood with integrated connectors for BPS 34 with three M 12 connectors
50037231	MS 34 105	Modular hood with integrated connectors for BPS 34 with five M 12 connectors

10.3 Accessory modular service display

Part No.	Type designation	Remark
50037232	MSD 1 101	Modular Service Display for BPS 34
50037543	KB 034-2000	Connection cable MS 34 105 to MSD 1 101

10.4 Accessory termination

Part No.	Type designation	Remark
50038539	TS 02-4-SA	M12 connector with integrated terminating resistor for DP OUT (B-coded)

10.5 Accessory connectors

Part No.	Type designation	Remark
50038538	KD 02-5-BA	M12 socket connector for DP IN (B-coded)
50038537	KD 02-5-SA	M12 plug connector for DP OUT (B-coded)
50020501	KD 095-5A	M12 connector for voltage supply (A-coded)

10.6 Accessory mounting device

Part No.	Type designation	Remark
50027375	BT 56	Mounting device with dovetail and rod

10.7 Accessory ready-made cables for voltage supply

10.7.1 Contact assignment of PWR IN connection cable

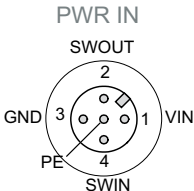
PWR connection cable (5-pin socket, A-coded)			
	Pin	Name	Core colour
 <p>PWR IN</p> <p>SWOUT</p> <p>GND 3 1 VIN</p> <p>PE 4</p> <p>SWIN</p> <p>M12 socket (A-coded)</p>	1	VIN	brown
	2	SWOUT	white
	3	GND	blue
	4	SWIN	black
	5	PE	grey
	Thread	PE	bare

10.7.2 Specifications of voltage supply cable

Operating temperature range in rest state: -30°C ... +70°C
in motion: -5°C ... +70°C

Material Sheathing: PVC

Bending radius > 50mm

10.7.3 Order codes for voltage supply cables

Part No.	Type designation	Remark
50104557	K-D M12A-5P-5m-PVC	M12 socket for PWR IN, axial connector, open line end, cable length 5m
50104559	K-D M12A-5P-10m-PVC	M12 socket for PWR IN, axial connector, open line end, cable length 10m

10.8 Accessory ready-made cables for PROFIBUS connection

10.8.1 General

- Cable **KB PB...** for connecting to the DP IN/DP OUT M12 connector
- Standard cables available in lengths from 2 ... 30m
- Special cables on request.

10.8.2 Contact assignment for PROFIBUS connection cable KB PB...

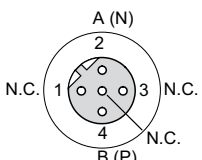
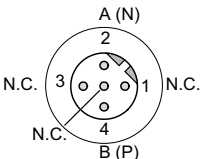
PROFIBUS connection cable (5-pin socket/connector, B-coded)			
	Pin	Name	Core colour
 <p>M12 socket (B-coded)</p>	1	N.C.	–
	2	A (N)	green
	3	N.C.	–
	4	B (P)	red
	5	N.C.	–
	Thread	FE	bare
 <p>M12 plug (B-coded)</p>			

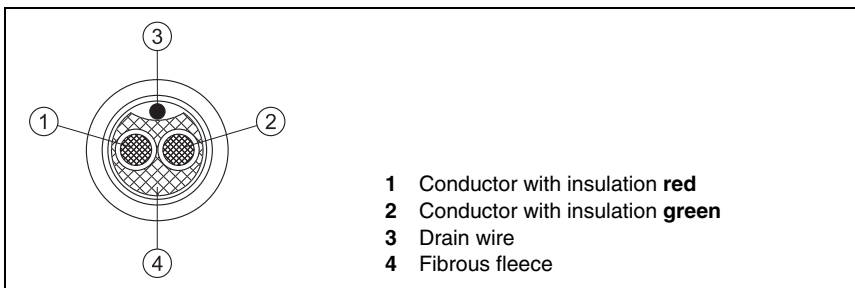

Figure 10.1: Cable structure of PROFIBUS connection cable

10.8.3 Specifications of PROFIBUS connection cable

Operating temperature range	in rest state: -40°C ... +80°C in motion: -5°C ... +80°C
Material	The lines fulfil the PROFIBUS requirements, free of halogens, silicone and PVC
Bending radius	> 80mm, suitable for drag chains

10.8.4 Order codes for PROFIBUS connection cables

Part No.	Type designation	Remark
50104181	KB PB-2000-BA	M12 socket for DP IN, axial connector, open line end, cable length 2m
50104180	KB PB-5000-BA	M12 socket for DP IN, axial connector, open line end, cable length 5m
50104179	KB PB-10000-BA	M12 socket for DP IN, axial connector, open line end, cable length 10m
50104178	KB PB-15000-BA	M12 socket for DP IN, axial connector, open line end, cable length 15m
50104177	KB PB-20000-BA	M12 socket for DP IN, axial connector, open line end, cable length 20m
50104176	KB PB-25000-BA	M12 socket for DP IN, axial connector, open line end, cable length 25m
50104175	KB PB-30000-BA	M12 socket for DP IN, axial connector, open line end, cable length 30m
50104188	KB PB-2000-SA	M12 plug for DP OUT, axial connector, open line end, cable length 2m
50104187	KB PB-5000-SA	M12 plug for DP OUT, axial connector, open line end, cable length 5m
50104186	KB PB-10000-SA	M12 plug for DP OUT, axial connector, open line end, cable length 10m
50104185	KB PB-15000-SA	M12 plug for DP OUT, axial connector, open line end, cable length 15m
50104184	KB PB-20000-SA	M12 plug for DP OUT, axial connector, open line end, cable length 20m
50104183	KB PB-25000-SA	M12 plug for DP OUT, axial connector, open line end, cable length 25m
50104182	KB PB-30000-SA	M12 plug for DP OUT, axial connector, open line end, cable length 30m
50104096	KB PB-1000-SBA	M12 plug, M12 socket for PROFIBUS, axial connectors, cable length 1m
50104097	KB PB-2000-SBA	M12 plug, M12 socket for PROFIBUS, axial connectors, cable length 2m
50104098	KB PB-5000-SBA	M12 plug, M12 socket for PROFIBUS, axial connectors, cable length 5m
50104099	KB PB-10000-SBA	M12 plug, M12 socket for PROFIBUS, axial connectors, cable length 10m
50104100	KB PB-15000-SBA	M12 plug, M12 socket for PROFIBUS, axial connectors, cable length 15m
50104101	KB PB-20000-SBA	M12 plug, M12 socket for PROFIBUS, axial connectors, cable length 20m
50104174	KB PB-25000-SBA	M12 plug, M12 socket for PROFIBUS, axial connectors, cable length 25m
50104173	KB PB-30000-SBA	M12 plug, M12 socket for PROFIBUS, axial connectors, cable length 30m

10.9 Type overview: Barcode tape

Part No.	Type designation	Remark
50038895	BCB 005	Barcode tape, 5m long
50040041	BCB 010	Barcode tape, 10m long
50037489	BCB 020	Barcode tape, 20m long
50037491	BCB 030	Barcode tape, 30m long
50037492	BCB 040	Barcode tape, 40m long
50038894	BCB 050	Barcode tape, 50m long
50038893	BCB 060	Barcode tape, 60m long
50038892	BCB 070	Barcode tape, 70m long
50038891	BCB 080	Barcode tape, 80m long
50038890	BCB 090	Barcode tape, 90m long
50037493	BCB 100	Barcode tape, 100m long
50040042	BCB 110	Barcode tape, 110m long
50040043	BCB 120	Barcode tape, 120m long
50040044	BCB 130	Barcode tape, 130m long
50040045	BCB 140	Barcode tape, 140m long
50040046	BCB 150	Barcode tape, 150m long
50037494	BCB 200	Barcode tape, 200m long
50037495	BCB / special lengths starting at 150m	Barcode tape with special length and special height
50102600	BCB special length 25mm high	Barcode tape with special length 25mm high

11 Maintenance

11.1 General maintenance information

Usually, the BPS 34 does not require any maintenance by the operator.

In the event of dust build-up, clean the optical window with a soft cloth; use a cleaning agent (commercially available glass cleaner) if necessary.

Also check the barcode tape for possible soiling.



Attention!

Do not use solvents and cleaning agents containing acetone. Use of improper cleaning agents can damage the optical window.

11.2 Repairs, servicing

Repairs to the device must only be carried out by the manufacturer.

↳ *Contact your Leuze distributor or service organisation should repairs be required. The addresses can be found on the inside of the cover and on the back.*



Notice!

When sending devices to Leuze electronic for repair, please provide an accurate description of the error.

11.3 Disassembling, packing, disposing

Repacking

For later re-use, the device is to be packed so that it is protected.



Notice!

Electrical scrap is a special waste product! Observe the locally applicable regulations regarding disposal of the product.

12 Appendix

12.1 EU Declaration of Conformity



Leuze electronic

EG-Konformitätserklärung

EC-Declaration of conformity

Hersteller:
HerstellerLeuze electronic GmbH + Co KG
In der Heiße 1
73277 Owen Teck
Deutschlanderklärt, unter alleiniger Verantwortung, dass die folgenden Produkte
den Bestimmungen der einschlägigen CE-Präzisionsnormen entsprechen

Gerätebeschreibung:

Beschreibung des Produkts: BPS 34 + MS 34

Folgende Richtlinien und Normen entsprechen
den einschlägigen Bestimmungen der CE-Präzisionsnormen

Zutreffende EG-Richtlinien:

Beschreibung des Produkts

89/336/EWG EMV-Richtlinie (EMC)
73/23/EWG Niederspannungsrichtlinie (Low Voltage Directive)

Angewandte harmonisierte Normen:

Spezifische Normen des Herstellers

EN 61000-6-2:2001 IEC 61000-6-2:2001 IEC 61000-6-2:2001 IEC 61000-6-2:2001
EN 61000-6-3:2001 IEC 61000-6-3:2001 IEC 61000-6-3:2001 IEC 61000-6-3:2001
EN 61000-4-2:2001 IEC 61000-4-2:2001 IEC 61000-4-2:2001 IEC 61000-4-2:2001
EN 61000-4-3:2001 IEC 61000-4-3:2001 IEC 61000-4-3:2001 IEC 61000-4-3:2001
EN 61000-4-4:1995 IEC 61000-4-4:1995 IEC 61000-4-4:1995 IEC 61000-4-4:1995
EN 61000-4-5:2001 IEC 61000-4-5:2001 IEC 61000-4-5:2001 IEC 61000-4-5:2001
EN 60925-1:1994 IEC 60925-1:1994 IEC 60925-1:1994 IEC 60925-1:1994

EN 55022:1998 + A1:2000 + A2:2003 IEC 61000-5:1998 + A1:2000 + A2:2003 IEC 61000-5:1998 + A1:2000 + A2:2003 IEC 61000-5:1998 + A1:2000 + A2:2003

EN 55024:1998 + A1:2001 + A2:2003 IEC 61000-6-1:1998 + A1:2001 + A2:2003 IEC 61000-6-1:1998 + A1:2001 + A2:2003 IEC 61000-6-1:1998 + A1:2001 + A2:2003

EN 61000-4-2:1995 + A1:1998 + A2:2001 IEC 61000-4-2:1995 + A1:1998 + A2:2001 IEC 61000-4-2:1995 + A1:1998 + A2:2001 IEC 61000-4-2:1995 + A1:1998 + A2:2001

EN 61000-4-3:2001 IEC 61000-4-3:2001 IEC 61000-4-3:2001 IEC 61000-4-3:2001

EN 61000-4-4:1995 IEC 61000-4-4:1995 IEC 61000-4-4:1995 IEC 61000-4-4:1995

EN 61000-4-5:2001 IEC 61000-4-5:2001 IEC 61000-4-5:2001 IEC 61000-4-5:2001

EN 60925-1:1994 IEC 60925-1:1994 IEC 60925-1:1994 IEC 60925-1:1994

Leuze electronic GmbH + Co KG
Postfach 31 11
In der Heiße 1
73277 Owen + Teck
Deutschland

Owen, den 13. 3. 06

Michael Heyne
(Geschäftsführer / managing director)Leuze electronic GmbH + Co KG
In der Heiße 1
73277 Owen Teck
DeutschlandDie Gesellschaft ist eine Kurzeinzelgesellschaft
im Sinne des § 12 Abs. 1 Nr. 1 S. 1 des
Handelsgesetzbuchs (HGB) und ist
eingetragen im Handelsregister des
Landesgerichtes Stuttgart, HRB 148620.
Geschäftsführer: Michael Heyne, Vorstand: Dr. Bernd Jähde
www.leuze-electronic.comLeuze Electronic GmbH
In der Heiße 1
73277 Owen Teck
Deutschland
Phone: +49 (0) 71 43 12 10
Fax: +49 (0) 71 43 12 1173277 Owen Teck
73277 Owen Teck
73277 Owen Teck
73277 Owen Teck73277 Owen Teck
73277 Owen Teck
73277 Owen Teck
73277 Owen Teck

A

Absolute accuracy 30
 Accessories 22, 94
 Connectors 94
 Modular hoods w. integrated connectors .94
 Modular service display 94
 Mounting device 94
 Ready-made cables 95, 96
 Termination 94
 Actual length 90
 Air pockets 30
 Angle of inclination 9, 39
 Areas of application 6

B

Barcode tape 27
 Cut mark 29
 defective 35
 Repair kit 35
 Type overview 98
 Wrapping direction 27
 Beam exit 8, 40
 Bonding surface 30
 BPS Configuration Tool 25
 Bus address 10, 45
 Bus termination 19

C

Cable
 PROFIBUS connection 96
 Voltage supply 95
 Calibration 90
 Caps 17, 18, 19, 43
 Causes of errors 92
 Cleaning 16
 Cleaning agents 99
 Commissioning steps at a glance 8
 Configuration tool 45
 Connection 16
 Accessories 22
 Functional earth PE 18
 Modular Service Display 12
 MSD 1 101 26
 PROFIBUS 10, 42
 Switching input 11
 Switching output 11

Voltage supply 9
 Connection assignment 17
 Connector unit 22
 Control barcode 32
 MVS 33
 Positioning 33
 Structure 32
 Core cross section 18
 Count direction 67
 cUL 3
 Curves 31
 Cut mark 29

D

DC bias level 61
 Debounce time 59
 Declaration of conformity 3, 100
 Default settings 76
 Description of functions 4
 Device arrangement 8, 40
 Device parameters 42
 Diagnosis 92
 Dimensioned drawing
 Connector unit 23
 Modular Service Display 26
 MS 34 105 23
 MS 34 103 23
 MSD 1 101 26
 Dimensioned drawings
 BPS 34 14
 MS 34 105 15
 MS 34 103 15
 Direction of movement 66
 Disassembling 99
 Disposing 99
 Double insulation 16
 Download 30
 GSE file 45
 DP IN 19, 43
 DP OUT 19, 43
 Dust 99

E

Electrical connection 16
 Error
 on PROFIBUS 92

Error case	75	Measurement error	68
Error output	75	Measurement length	65
EU Declaration of Conformity	100	Measurement start mode	63
Expansion joints	30	Velocity	80
F		Measurement stop mode	63
Factory settings	76	Velocity	80
Fastening grooves	37	Measurement value switching	33
Faults	16	Measuring error tolerance	75
G		Minimum velocity	84
Gap	29	Modular hood with integrated connectors	
GSE file	42, 45	MS 34 103	22
GSE modules		Modular Service Display	25
Overview	47	Module	
Structure	46	Control	63
H		Dynamic position limit value 1	73
Heating		Dynamic position limit value 2	74
Integrated	18, 41	Dynamic preset	55
Hood with integrated connectors	22	Dynamic velocity limit value	88
I		Measurement value acquisition	65
Input data	42	Measurement value preparation	66
Integrated heating	41	Measuring error tolerance	75
Integration depth	66, 78	Min/Max position	69
Integration error	75	Min/Max velocity	84
Integration time	79	Offset value	56
Intended use	5	Position value	51
Interface		Resolution	52
PROFIBUS	42	Scaling	57
L		Service	76
Laser radiation	6	Static position limit value 1	71
LED states	24	Static position limit value 2	72
Length deviation	90	Static preset	53
Limit value	71, 72, 73, 74, 85	Static velocity limit values	85
Limit velocity	85	Status	68
Limits	68	Switching input	59
M		Switching output	61
Maintenance	99	Tape value correction	90
Maximum velocity	84	Velocity	77
		Velocity measurement control	80
		Velocity measurement status	82
		Velocity parameters	78
		Modules	47
		Mounting	37
		Angle of inclination	39
		Barcode tape	8, 29, 41
		BPS 34	37
		BT 56	37
		Device	8
		Mounting device	37

Outdoors41
 Mounting device
 BT 5637
 Mounting example39
 Mounting location40
 Mounting surface30
 Moving system9
 MS 34 10322
 MSD 1 10125
 MVS33

N

Name plate 7, 16
 Nominal length90

O

Optical window99
 Order codes
 PROFIBUS connection cable97
 Voltage supply cable95
 Output data42
 Overview
 Modules47

P

Packing99
 Parameter memory25
 Position limit value 71, 72, 73, 74
 Position value51
 Positioning
 Control barcode33
 Power supply unit16
 Preset value 53, 55
 PROFIBUS42
 Address45
 Communication24
 DP42
 Error92
 GSE file42
 Incoming 19, 43
 Outgoing 19, 43
 Project25
 PROFIBUS address10
 PROFIBUS manager11
 Protection class 17, 18, 19, 43

protective conductor 16
 Protective housing 41
 Pulse duration 59, 61
 PWR IN 18

Q

Quality assurance 3

R

Range end 90
 Range start 90
 Reading field
 Curve 21
 Read distance 21
 Width 21
 Working range 21
 Real length 90
 Repair 5, 99
 Repair kit 35
 Download 35
 Reset 76
 Resolution 52
 Rod mounting 37
 Rotary switch 10

S

Safety notices 5
 Safety transformer 16
 Scaling 78
 Scaling factor 57
 Service 76
 Service fax 93
 Service interface 24, 25
 Service order 93
 Servicing 99
 Slide switch 10
 Soiling 41
 Specifications 13
 Barcode tape 14, 28
 Connector units 22
 Electrical data 13
 Environmental data 13
 Measurement data 13
 Mechanical data 13
 Optical data 13

PROFIBUS connection cable	.97
Voltage supply cable	.95
Start-up delay	.59
Status	
PROFIBUS	.24
Status information	68, 82
Status LED	.24
Sub-D connector	.26
Supply voltage	.16
SW IN/OUT	.20
Switching input	20, 59
Switching output	.20
Switch-off delay	.60
Switch-off function	.62
Switch-on function	.61
Symbols	.3

T

Tape height	9, 39
Tape switching	.34
Tape value correction	.90
Termination	
Connector TS 02-4-SA	.19
Total reflection	.40
Troubleshooting	.92
Type overview	.94
Barcode tape	.98
BPS 34	.94

U

Universal module	.46
------------------	-----

V

Velocity	.77
Velocity limit value	.88
Velocity measurement	78, 80, 82
Velocity parameter	.78

W

Warning label and certification label	.7
Working range	.21



Leuze electronic GmbH + Co. KG
 P. O. Box 11 11, D-73277 Owen / Teck
 Tel. +49(0) 7021/ 573-0,
 Fax +49(0) 7021/ 573-199
 E-mail: info@leuze.de, www.leuze.de

Sales and Service

Sales Region North

Phone 07021/573-306
 Fax 07021/9850950

Postal code areas

20000-38999
 40000-53999
 56000-65999
 97000-97999



Sales Region East

Phone 035027/629-106
 Fax 035027/629-107

Postal code areas

01000-19999
 39000-39999
 98000-99999

Sales Region South

Phone 07021/573-307
 Fax 07021/9850911

Postal code areas

54000-55999
 66000-96999

Worldwide

AR (Argentina)

Nortécnica S. R. L.
 Tel. Int. + 54 (0) 11/4757-3129
 Fax Int. + 54 (0) 11/4757-1088

AT (Austria)

Ing. Franz Schmachtl KG
 Tel. Int. + 43 (0) 732/7646-0
 Fax Int. + 43 (0) 732/765036

AU + NZ (Australia + New Zealand)

Balluff-Leuze Pty. Ltd.
 Tel. Int. + 61 (0) 3/97642366
 Fax Int. + 61 (0) 3/97533262

BE (Belgium)

Leuze electronic nv/sa
 Tel. Int. + 32 (0) 2/2531600
 Fax Int. + 32 (0) 2/2531536

BR (Brazil)

Leuze electronic Ltda.
 Tel. Int. + 55 (0) 11/4195-6134
 Fax Int. + 55 (0) 11/4195-6177

CH (Switzerland)

Leuze electronic AG
 Tel. Int. + 41 (0) 1/8340204
 Fax Int. + 41 (0) 1/8332626

CL (Chile)

Imp. Tec. Vignola S.A.I.C.
 Tel. Int. + 56 (0) 32/351111
 Fax Int. + 56 (0) 32/351128

CN (China)

Leuze electronic GmbH + Co. KG
 Shanghai Representative Office
 Tel. Int. + 86(0)21/68880920
 Fax Int. + 86(0)21/68880919

CO (Colombia)

Componentes Electronicas Ltda.
 Tel. Int. + 57 (0) 4/3511049
 Fax Int. + 57 (0) 4/3511019

CZ (Czech Republic)

Schmachtl CZ s.r.o.
 Tel. Int. + 420 (0) 2/44001500
 Fax Int. + 420 (0) 2/44910700

DK (Denmark)

Desim Elektronik APS
 Tel. Int. + 45/70220066
 Fax Int. + 45/70222220

ES (Spain)

Leuze electronic S.A.
 Tel. Int. + 34 93/4097900
 Fax Int. + 34 93/4905820

FI (Finland)

SKS-automaatio Oy
 Tel. Int. + 358 (0) 9/852661
 Fax Int. + 358 (0) 9/8526820

FR (France)

Leuze electronic sarl.
 Tel. Int. + 33 (0) 1/60051220
 Fax Int. + 33 (0) 1/60050365

GB (United Kingdom)

Leuze Mayer electronic Ltd.
 Tel. Int. + 44 (0) 1480/408500
 Fax Int. + 44 (0) 1480/403808

GR (Greece)

UTEKO A.B.E.E.
 Tel. Int. + 30 (0) 210/4210050
 Fax Int. + 30 (0) 210/4212033

HK (Hong Kong)

Sensortech Company
 Tel. Int. + 852/26510188
 Fax Int. + 852/26510388

HU (Hungary)

Kvalix Automatika Kft.
 Tel. Int. + 36 (0) 1/2722242
 Fax Int. + 36 (0) 1/2722244

IL (Israel)

Galoz electronics Ltd.
 Tel. Int. + 972 (0) 3/9023456
 Fax Int. + 972 (0) 3/9021990

IN (India)

Global Tech (India) Pvt. Ltd.
 Tel. Int. + 91 (0) 20/24470085
 Fax Int. + 91 (0) 20/24470086

IR (Iran)

Tavan Ressian Co. Ltd.
 Tel. Int. + 98 (0) 21/2606766
 Fax Int. + 98 (0) 21/2002883

IT (Italy)

Leuze electronic S.r.l.
 Tel. Int. + 39 02/2611 0643
 Fax Int. + 39 02/2611 0640

JP (Japan)

C. Illies & Co., Ltd.
 Tel. Int. + 81 (0) 3/34434111
 Fax Int. + 81 (0) 3/34434118

KR (South Korea)

Leuze electronic Co., Ltd.
 Tel. Int. + 82 (0) 31/3828228
 Fax Int. + 82 (0) 31/3828522

MX (Mexico)

Leuze Lumiflex México, S.A. de C.V.
 Tel. Int. + 52 (0) 81/83 71 86 16
 Fax Int. + 52 (0) 81/83 71 85 88

MY (Malaysia)

Ingenmark (M) SDN.BHD
 Tel. Int. + 60 (0) 3/60342788
 Fax Int. + 60 (0) 3/60342188

NL (Netherlands)

Leuze electronic B.V.
 Tel. Int. + 31 (0) 418/653544
 Fax Int. + 31 (0) 418/653808

NO (Norway)

Eiteco AS
 Tel. Int. + 47 (0) 35/562070
 Fax Int. + 47 (0) 35/562099

PL (Poland)

Balluff Sp. z o.o.
 Tel. Int. + 48 (0) 22/8331564
 Fax Int. + 48 (0) 22/8330969

PT (Portugal)

LA2P, Lda.
 Tel. Int. + 351 (0) 21/4447070
 Fax Int. + 351 (0) 21/4447075

RO (Romania)

O'Boyle s.r.l.
 Tel. Int. + 40 (0) 56/201346
 Fax Int. + 40 (0) 56/221036

RU (Russian Federation)

All Impex
 Tel. + Fax + 7 095/ 9332097

SE (Sweden)

Leuze Sensorgruppen AB
 Tel. + 46 (0) 8/731 51 90
 Fax + 46 (0) 8/731 51 05

SG + PH + ID (Singapore + Philippines + Indonesia)

Balluff Asia Pte. Ltd.
 Tel. Int. + 65/62524384
 Fax Int. + 65/62529606

SI (Slovenia)

Tipteh d.o.o.
 Tel. Int. + 386 (0) 1/2005150
 Fax Int. + 386 (0) 1/2005151

SK (Slovakia)

Schmachtl SK s.r.o.
 Tel. Int. + 421 (0) 2/58275600
 Fax Int. + 421 (0) 2/58275601

TH (Thailand)

Industrial Electrical Co. Ltd.
 Tel. Int. + 66 (0) 2/6 42-6700
 Fax Int. + 66 (0) 2/6 42-4249

TR (Turkey)

Balluff Sensör Ltd. Sti.
 Tel. Int. + 90 (0) 212/3200411
 Fax Int. + 90 (0) 212/3200416

TW (Taiwan)

Great Cotue Technology Co., Ltd.
 Tel. Int. + 886 (0) 2/29838077
 Fax Int. + 886 (0) 2/29853373

UA (Ukraine)

Bevter/Foods Ltd.
 Tel. Int. + 38 044/5255927
 Fax Int. + 38 044/5257807

US + CA (United States + Canada)

Leuze Lumiflex Inc.
 Tel. Int. + 1 (0) 248/4 864466
 Fax Int. + 1 (0) 248/4 866699

ZA (South Africa)

Countapulse Controls (PTY.) Ltd.
 Tel. Int. + 27 (0) 11/6157556
 Fax Int. + 27 (0) 11/6157513